



Brushless Motor and Driver Package

BMU Series

OPERATING MANUAL



Thank you for purchasing an Oriental Motor product.

This Operating Manual describes product handling procedures and safety precautions.

- Please read it thoroughly to ensure safe operation.
- Always keep the manual where it is readily available.

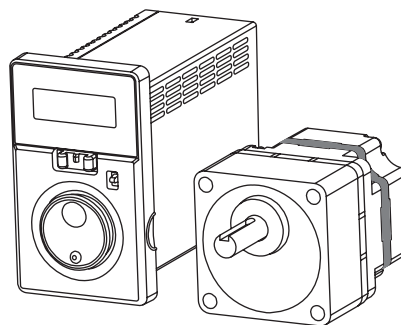

The "NexBL" is a new brushless motor offered by Oriental Motor. The utmost performance required for the motor is pursued, and all the structures of the motor have been renewed.

This product achieves more compact, higher power and higher efficiency than ever before.

Only qualified and educated personnel should work with the product.

Use the product correctly after thoroughly reading the section "1 Safety precautions".

The product described in this manual has been designed and manufactured to be incorporated in general industrial equipment. Do not use for any other purpose. Oriental Motor Co., Ltd. is not responsible for any damage caused through failure to observe this warning.



The product is a motor and driver package product consisting of a slim, high-power brushless motor and panel-installation type driver. This driver having a built-in digital display enables to control the motor speed easily by turning the setting dial while checking the speed on the display.

Table of contents

1	Safety precautions.....	3	7	Functions.....	19
2	Precautions for use	5	7.1	Functions list	19
3	Preparation.....	6	7.2	Transition of display on the driver	20
3.1	Checking the product	6	7.3	Parameter list.....	22
3.2	How to identify the product model.....	6	7.4	Items displayed on the driver	23
3.3	Combinations of motors and drivers	6	7.5	Setting the operation data.....	24
3.4	Names and functions of parts	7	7.6	Setting the acceleration time and deceleration time.....	24
4	Operating the motor	8	7.7	Disabling an operation with the setting dial	25
4.1	Connecting	8	7.8	Operating with external signals	25
4.2	Inputting the power.....	8	7.9	Operating with multiple speeds	27
4.3	Operating	9	7.10	Limiting the setting range of the rotation speed	28
■	Running the motor.....	9	7.11	Holding a load at motor standstill	28
■	Adjusting the speed.....	9	8	Alarms and warnings.....	29
■	Determining the speed.....	9	8.1	Alarms	29
■	Stopping the motor.....	9	8.2	Warnings	31
■	Changing the rotation direction	9	9	Inspection/Troubleshooting and remedial actions	32
5	Installation	10	9.1	Inspection.....	32
5.1	Installation location.....	10	9.2	Troubleshooting and remedial actions	33
5.2	Installing the motor.....	10	10	Accessories (sold separately)	34
■	Installing the combination parallel shaft gearhead.....	10	11	Reference.....	35
■	Removing/Installing the gearhead.....	11	11.1	Standard and CE Marking.....	35
■	Installing the round shaft type	11	11.2	Installing and wiring in compliance with EMC Directive.....	36
■	Installing a load	12	11.3	Specifications	38
■	Permissible radial load and permissible axial load.....	12			
5.3	Installing the driver	13			
6	Connection	14			
6.1	Connecting the power supply	14			
6.2	Connecting the motor.....	14			
6.3	Grounding	15			
6.4	Connecting the I/O signals	15			
6.5	Connection example	17			



1 Safety precautions

The precautions described below are intended to prevent danger or injury to the user and other personnel through safe, correct use of the product. Please read and understand these precautions thoroughly before using the product.

 Warning	Handling the product without observing the instructions that accompany a “Warning” symbol may result in serious injury or death.
 Caution	Handling the product without observing the instructions that accompany a “Caution” symbol may result in injury or property damage.
Note	The items under this heading contain important handling instructions that the user should observe to ensure the safe use of the product.

Warning

General

- Do not use the product in explosive or corrosive environments, in the presence of flammable gases or near combustibles. Doing so may result in fire, electric shock or injury.
- Only qualified and educated personnel should be allowed to perform installation, connection, operation and inspection/troubleshooting of the product. Handling by unqualified and uneducated personnel may result in fire, electric shock, injury or equipment damage.
- Do not transport, install the product, perform connections or inspections when the power is on. Always turn the power off before carrying out these operations. Failure to do so may result in electric shock or equipment damage.
- The terminals on the driver front panel marked with   symbol indicate the presence of high voltage. Do not touch these terminals while the power is on. Doing so may result in fire or electric shock.
- Do not use a motor in a vertical application. If the driver’s protection function is activated, the motor will stop and the moving part of the equipment will drop, thereby causing injury or equipment damage.
- If the driver protective function was activated, remove the cause and reset the protective function. Continuing the operation without removing the cause of the problem may result in malfunction of the motor and driver, leading to injury or damage to equipment.

Installation

- The motor and driver are Class I equipment.
When installing the motor and driver, connect their Protective Earth Terminals. Failure to do so may result in electric shock.

Connection

- Securely connect the cables in accordance with the connection examples. Failure to do so may result in fire or electric shock.
- Do not forcibly bend, pull or pinch the cables. Doing so may result in fire or electric shock.
- Do not machine or modify the motor cable or connection cable. Doing so may result in electric shock or fire.
- Be sure to observe the specified cable sizes. Use of unspecified cable sizes may result in fire.

Operation

- Use a motor (gearhead) and driver only in the specified combination. An incorrect combination may cause in fire, electric shock or equipment damage.
- Keep the input power voltage of the driver within the specified range. Failure to do so may result in fire or electric shock.

Maintenance and inspection

- Always turn off the power before performing maintenance/inspection. Failure to do so may result in electric shock.
- Do not touch the motor or driver when conducting insulation resistance measurement or dielectric strength test. Accidental contact may result in electric shock.
- Do not touch the connection terminals on the driver immediately (within 1 minute) after the power is turned off. Residual voltage may cause electric shock.
- Regularly check the openings in the driver for accumulated dust. Accumulated dust may cause fire.

Repair, disassembly and modification

- Do not disassemble or modify the motor (gearhead) and driver. Doing so may result in electric shock, injury or equipment damage. Should you require inspection or repair of internal parts, please contact the Oriental Motor branch or sales office from which you purchased the product.

 **Caution**

General

- Do not use the motor (gearhead) and driver beyond the specifications. Doing so may result in fire, electric shock, injury or damage to equipment.
- Do not insert an object into the openings in the driver. Doing so may result in fire, electric shock or injury.
- Do not touch the motor (gearhead) or driver while operating or immediately after stopping. The surface of the motor (gearhead) or driver may be hot and cause a skin burn(s).

Installation

- Do not leave anything around the motor and driver that would obstruct ventilation. Doing so may result in damage to equipment.
- Do not carry the product by holding the motor (gearhead) output shaft or any of the cables. Doing so may result in injury.
- Do not touch the motor output shaft (key slot or pinion) with bare hands. Doing so may result in injury.
- When assembling the motor (pinion shaft) with the gearhead, exercise caution not to pinch your fingers or other parts of your body between the motor and gearhead. Injury may result.
- Securely install the motor (gearhead) and driver to their respective mounting plates. Inappropriate installation may cause the motor/driver to detach and fall, resulting in injury or equipment damage.
- Provide a cover on the rotating part (output shaft) of the motor (gearhead). Failure to do so may result in injury.
- When installing the motor (gearhead) in the equipment, exercise caution not to pinch your fingers or other parts of your body between the equipment and motor or gearhead. Injury may result.
- Securely install the load on the motor (gearhead) output shaft. Inappropriate installation may result in injury.

Connection

- For the power supply of I/O signals, use a DC power supply with reinforced insulation on its primary and secondary sides. Failure to do so may result in electric shock.

Operation

- Provide an emergency stop device or emergency stop circuit external to the equipment so that the entire equipment will operate safely in the event of a system failure or malfunction. Failure to do so may result in injury.
- Immediately when trouble has occurred, stop running and turn off the driver power. Failure to do so may result in fire, electric shock or injury.
- Do not touch the rotating part (output shaft) when operating the motor. Doing so may result in injury.
- The motor surface temperature may exceed 70 °C (158 °F) even under normal operating conditions. If the operator is allowed to approach a running motor, attach a warning label as shown in the figure in a conspicuous position. Failure to do so may result in skin burn(s).
- Use an insulated screwdriver to adjust the acceleration/ deceleration time potentiometer in the driver. Failure to do so may result in electric shock.



Warning label

Disposal

- To dispose of the motor (gearhead) or driver, disassemble it into parts and components as much as possible and dispose of individual parts/components as industrial waste.

■ **Warning information**

A warning label with handling instructions is attached on the driver. Be sure to observe the instructions on the label when handling the driver.

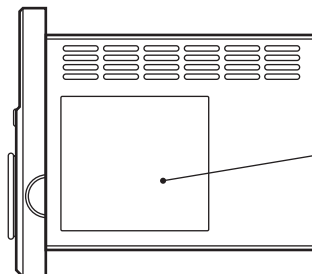

WARNING – Risk of electric shock. Hot Surface	
	• Read manual before installing.
	• Wait 1 minute for capacitor discharge after disconnecting power supply.
	• Do not touch the heatsink. Risk of burn.
AVERTISSEMENT – Risque de décharge électrique. Surface chaude	
	• Lire le manuel avant l'installation.
	• Attendre 1 minute après la coupure de l'alimentation, pour permettre la décharge des condensateurs.
	• Ne pas toucher le dissipateur thermique. Risque de brûlure.
警告 – けが・感電のおそれがあります。 高温注意	
	• 据え付け、運転の前には必ず取扱説明書をお読み下さい。
	• 通電中及び電源遮断後 1 分以内はドライバに触れないで下さい。残留電圧により感電の原因となります。
	• ヒートシンクは高温になります。やけどに注意して下さい。

2 Precautions for use

This chapter covers limitations and requirements the user should consider when using the product.

- **Connect protective devices to the power line**

Connect a circuit breaker or earth leakage breaker to the driver's power line to protect the primary circuit.

If an earth leakage breaker is to be installed, use one incorporating high-frequency noise elimination measures. Refer to "Preventing leakage current" below for the selection of protective devices.

- **Do not perform vertical drive (gravitational operation).**

The product will not be able to control the motor speed if an operation that the motor output shaft is externally rotated is performed (vertical drive etc.). Also, if vertical drive is performed, since the inverter primary voltage of the circuit may exceed the permissible range, the protective function may be activated. As a result, the motor may coast to a stop and the load may fall.

- **Do not use a solid-state relay (SSR) to turn on/off the power**

A circuit that turns on/off the power via a solid-state relay (SSR) may damage the motor and driver.

- **Conduct insulation resistance measurement or dielectric strength test separately on the motor and the driver**

Conducting the insulation resistance measurement or dielectric strength test with the motor and driver connected may result in damage to the product.

- **Grease measures**

On rare occasions, a small amount of grease may ooze out from the gearhead. If there is concern over possible environmental damage resulting from the leakage of grease, check for grease stains during regular inspections.

Alternatively, install an oil pan or other device to prevent leakage from causing further damage. Oil leakage may lead to problems in the customer's equipment or products.

- **Caution when using under low temperature environment**

When an ambient temperature is low, since the load torque may increase by the oil seal or viscosity increment of grease used in the gearhead, the output torque may decrease or an overload alarm may generate. However, as time passes, the oil seal or grease is warmed up, and the motor can be driven without generating an overload alarm.

- **Preventing leakage current**

Stray capacitance exists between the driver's current-carrying line and other current-carrying lines, the earth and the motor, respectively. A high-frequency current may leak out through such capacitance, having a detrimental effect on the surrounding equipment. The actual leakage current depends on the driver's switching frequency, the length of wiring between the driver and motor, and so on. When connecting an earth leakage breaker, use one of the following products offering resistance against high frequency current:

Mitsubishi Electric Corporation: NV series

Fuji Electric FA Components & Systems Co., Ltd.: EG and SG series

- **Noise elimination measures**

Provide noise elimination measures to prevent a motor or driver malfunction caused by external noise. For more effective elimination of noise, use a shielded I/O signal cable or attach ferrite cores if a non-shielded cable is used. Refer to p.36 for the noise elimination measures.

- **Connecting the motor and driver**

Use a connection cable (supplied or accessory) when extending the wiring distance between the motor and driver.

- **The driver uses semiconductor elements, so be extremely careful when handling them.**

Electrostatic discharge can damage the driver.

- **Saving data to the non-volatile memory**

The display blinks while pressing the setting dial to set the data or initializing the data (about 5 seconds). Do not turn off the power supply while the display is blinking. Doing so may abort writing the data and cause an EEPROM error alarm to generate.

The non-volatile memory can be rewritten approximately 100,000 times.

3 Preparation

This chapter explains the items you should check, as well as the names and functions of each part.

3.1 Checking the product

Verify that the items listed below are included. Report any missing or damaged items to the branch or sales office from which you purchased the product.

- Motor 1 unit
(With a gearhead, only for combination type)
- Driver 1 unit
- Connection cable 1 pc
(Only models with a supplied connection cable)
- OPERATING MANUAL (this document) 1 copy
- CN1 connector (3 pins) 1 pc
- CN4 connector (9 pins) 1 pc
- Accessories for combination type parallel shaft gearhead
 - Hexagonal socket head screw set 1 set
(Hexagonal socket head screw, flat washer, spring washer and nut, 4 pcs. each)
 - Parallel key 1 pc

3.2 How to identify the product model

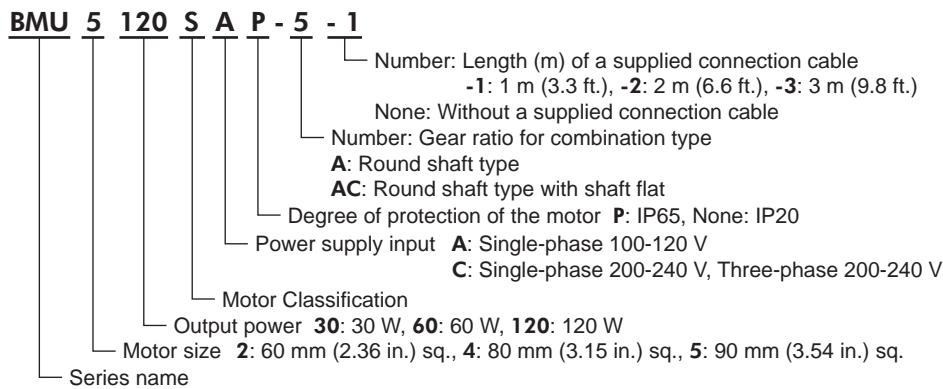

3.3 Combinations of motors and drivers

Verify the model number of the purchased product against the number shown on the package label. Check the model number of the motor and driver against the number shown on the nameplate.

■ indicates the cable length (**-1**, **-2**, **-3**) when the connection cable is supplied.

■ Combination type parallel shaft gearhead

- □ in the model name indicates a number representing the gear ratio.
- The combination types come with the motor and gearhead pre-assembled.

Output power	Degree of protection of the motor *	Power supply voltage	Model	Motor model	Gearhead model	Driver model
30 W	IP20	Single-phase 100-120 V	BMU230A-□■	BLM230-GFV	GFV2G□	BMUD30-A
		Single-phase/Three-phase 200-240 V	BMU230C-□■			BMUD30-C
	IP65	Single-phase 100-120 V	BMU230AP-□■	BLM230P-GFV		BMUD30-A
		Single-phase/Three-phase 200-240 V	BMU230CP-□■			BMUD30-C
60 W	IP20	Single-phase 100-120 V	BMU460SA-□■	BLM460S-GFV	GFV4G□	BMUD60-A
		Single-phase/Three-phase 200-240 V	BMU460SC-□■			BMUD60-C
	IP65	Single-phase 100-120 V	BMU460SAP-□■	BLM460SP-GFV		BMUD60-A
		Single-phase/Three-phase 200-240 V	BMU460SCP-□■			BMUD60-C
120 W	IP20	Single-phase 100-120 V	BMU5120A-□■	BLM5120-GFV	GFV5G□	BMUD120-A
		Single-phase/Three-phase 200-240 V	BMU5120C-□■			BMUD120-C
	IP65	Single-phase 100-120 V	BMU5120AP-□■	BLM5120P-GFV		BMUD120-A
		Single-phase/Three-phase 200-240 V	BMU5120CP-□■			BMUD120-C

* Excluding the connector part

■ Round shaft type

◆ in the model name indicates **A** (no machining) or **AC** (shaft flat) for the round shaft type.

Output power	Degree of protection of the motor *	Power supply voltage	Model	Motor model	Driver model
30 W	IP20	Single-phase 100-120 V	BMU230A-◆■	BLM230-◆	BMUD30-A
		Single-phase/Three-phase 200-240 V	BMU230C-◆■		BMUD30-C
	IP65	Single-phase 100-120 V	BMU230AP-◆■	BLM230P-◆	BMUD30-A
		Single-phase/Three-phase 200-240 V	BMU230CP-◆■		BMUD30-C
60 W	IP20	Single-phase 100-120 V	BMU260A-◆■	BLM260-◆	BMUD60-A
		Single-phase/Three-phase 200-240 V	BMU260C-◆■		BMUD60-C
	IP65	Single-phase 100-120 V	BMU260AP-◆■	BLM260P-◆	BMUD60-A
		Single-phase/Three-phase 200-240 V	BMU260CP-◆■		BMUD60-C
120 W	IP20	Single-phase 100-120 V	BMU5120A-◆■	BLM5120-◆	BMUD120-A
		Single-phase/Three-phase 200-240 V	BMU5120C-◆■		BMUD120-C
	IP65	Single-phase 100-120 V	BMU5120AP-◆■	BLM5120P-◆	BMUD120-A
		Single-phase/Three-phase 200-240 V	BMU5120CP-◆■		BMUD120-C

* Excluding the motor mounting surface and connector part

3.4 Names and functions of parts

■ Motor

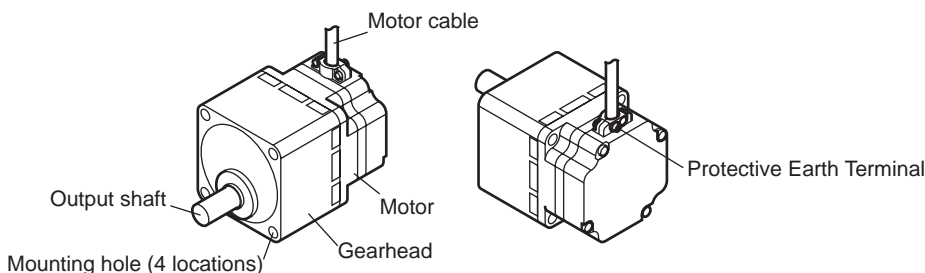

■ Driver

● Driver front side: When the front panel is attached

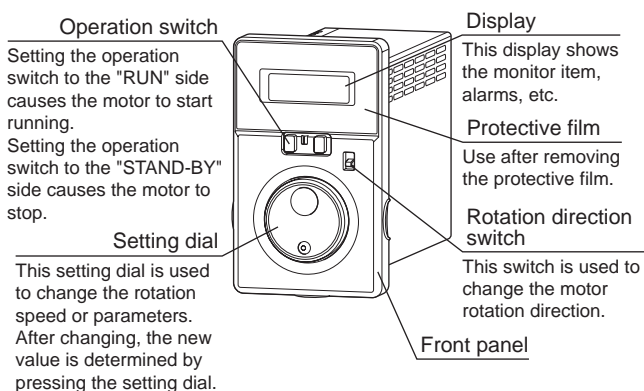

● Driver front side: When the front panel is removed

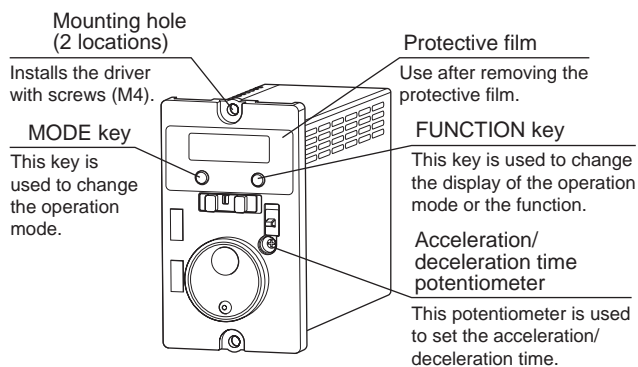

● Driver rear side

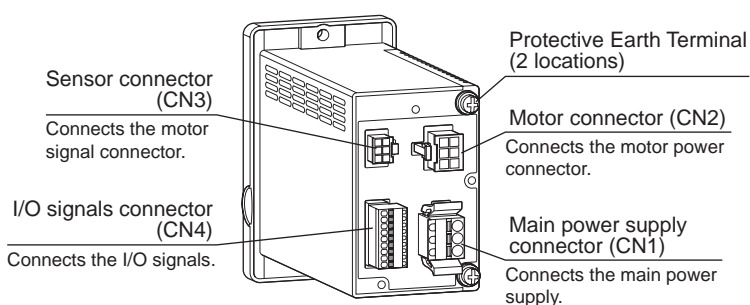

4 Operating the motor

This section explains how to operate the product with ease at the factory setting when receiving the product.

4.1 Connecting

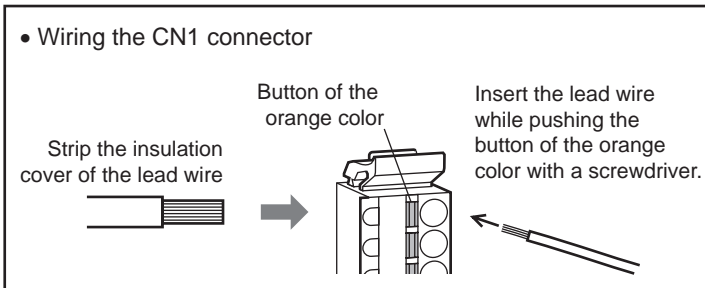
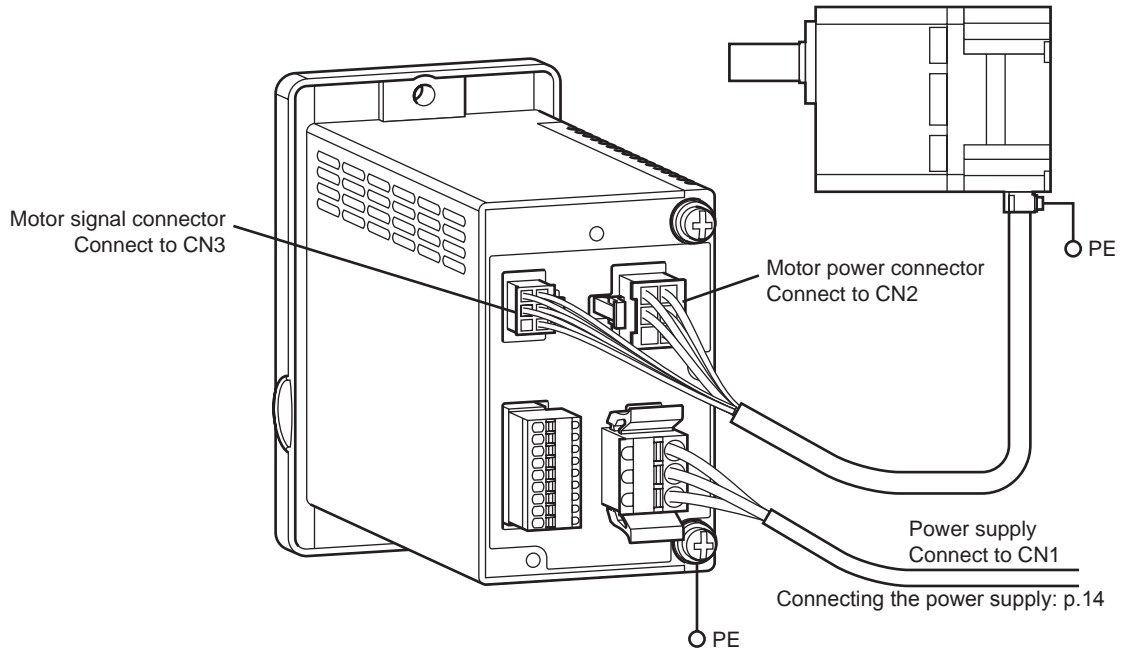

- Note**
- When cycling the power or plugging/unplugging the connector, turn off the power and wait for 1 minute or more before doing so.
 - Ensure that the connector plugged in securely. Insecure connections may cause malfunction or damage to the product.

4.2 Inputting the power

Turn on the power after connecting as shown in the figure above.

- Note**
- When inputting the power, if the operation switch is set to the RUN side, the alarm code "AL46" (prevention of operation at power-on) is displayed, and the operation cannot be executed. Set the operation switch to the STAND-BY side and turn on the power.

* Refer to p.29 for "prevention of operation at power-on" (alarm code: AL46).

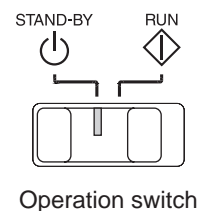

Refer to the next page "4.3 Operating" for how to operate.

4.3 Operating

After turning on the power, operate the product as follows.

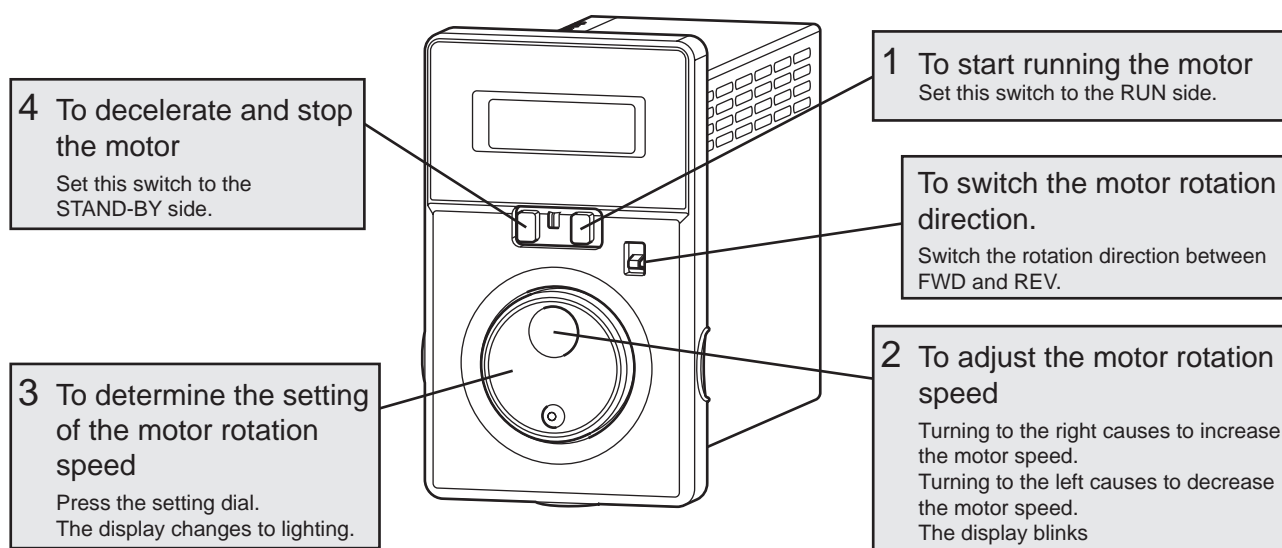

■ Running the motor

Setting the operation switch to the RUN side and turning the setting dial to the right causes the motor to start rotating.

■ Adjusting the speed

When turning the setting dial to the right slowly, the rotation speed accelerates by 1 r/min increments. When turning the setting dial to the left slowly, the rotation speed decelerates by 1 r/min increments.

When turning the setting dial quickly, the amount of the rotation speed change increases.

■ Determining the speed

• Set

When pressing the setting dial, the rotation speed is determined.

When the display is blinking, the rotation speed has not set yet. Determine it by pressing the setting dial.
(The set data is saved in the operation data No.0. Refer to p.20 for details.)

• Confirmation

If the setting dial is pressed while the motor stops, the set speed is displayed blinking (several times).

Operating with the setting dial can be limited by the lock function so that the set rotation speed cannot be changed.
Refer to the p.25 "7.7 Disabling an operation with the setting dial" for details.

■ Stopping the motor

Setting the operation switch to the STAND-BY side causes the motor to decelerate to a stop.

Setting the operation switch again to the RUN side causes the motor to start rotating at the set rotation speed.

■ Changing the rotation direction

Change the rotation direction of the motor (gearhead) using the rotation direction switch. The rotation direction can be changed while operating.

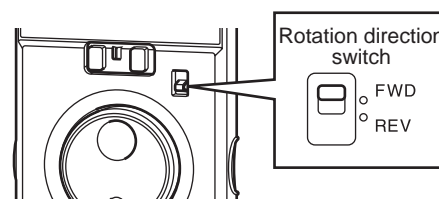

With the combination type, the rotation direction of the gearhead output shaft varies depending on the gear ratio of the gearhead. Refer to p.25 "Rotation direction" for details.

5 Installation

This chapter explains the installation location and installation methods of the motor and driver, as well as how to install a load.

5.1 Installation location

Install the motor in a well-ventilated place where they can be inspected easily and the following conditions are satisfied:

[Common conditions]

- Ambient temperature: 0 to +40 °C (+32 to +104 °F) (non-freezing)
- Ambient humidity: 85% or less (non-condensing)
- Area that is free of explosive atmosphere or toxic gas (such as sulfuric gas) or liquid
- Area not exposed to direct sun
- Area free of excessive amount of dust, iron particles or the like
- Area free of excessive salt
- Area not subject to continuous vibration or excessive shocks
- Area free of excessive electromagnetic noise (from welders, power machinery, etc.)
- Area free of radioactive materials, magnetic fields or vacuum
- Altitude: Up to 1000 m (3300 ft.) above sea level

[Degree of protection IP65 rated motor]

- Indoors
- Not exposed to oil (oil droplets) or chemicals.
This motor can be used in an environment that is splashed with water (excluding the connector part and the mounting surface of the round shaft type).
Not available for use under high pressure jets of water or immersion in water.

[Degree of protection IP20 rated motor]

- Inside an enclosure installed indoors (provide a ventilation hole)
- Area not subject to splashing water (rain, water droplets), oil (oil droplets) or other liquids

5.2 Installing the motor

■ Installing the combination parallel shaft gearhead

Secure the motor with hexagonal socket head screws (supplied) through the four mounting holes provided. Do not leave a gap between the motor and mounting plate.

- Hexagonal socket head screw set (supplied)

Model	Gear ratio	Hexagonal socket head screw		Tightening torque [N·m (lb-in)]
		Screw size	Screw length [mm (in.)]	
BMU230	5 to 20	M4	50 (1.97)	1.8 (15.9)
	30 to 100		55 (2.17)	
	200		60 (2.36)	
BMU460S	5 to 20	M6	60 (2.36)	6.4 (56)
	30 to 100		65 (2.56)	
	200		70 (2.76)	
BMU5120	5 to 20	M8	70 (2.76)	15.5 (137)
	30 to 100		85 (3.35)	
	200		90 (3.54)	

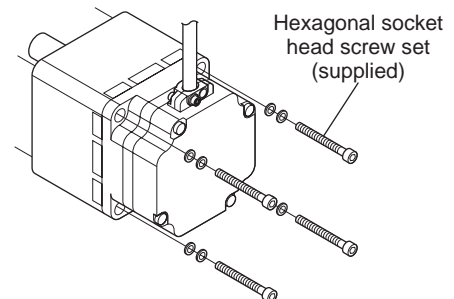

- Mounting hole dimensions

[Unit: mm (in.)]

Model	ØA	B	ØC	D
BMU230	70 (2.76)	49.50 (1.949)	$23^{+0.021}_0$ (0.9055 $^{+0.0008}_0$)	10 (0.39)
BMU460S	94 (3.70)	66.47 (2.617)	$33^{+0.025}_0$ (1.2992 $^{+0.0010}_0$)	13 (0.51)
BMU5120	104 (4.09)	73.54 (2.895)	$39^{+0.025}_0$ (1.5354 $^{+0.0010}_0$)	18 (0.71)

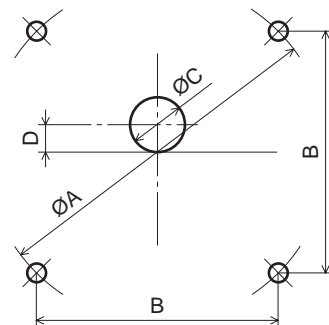

■ Removing/Installing the gearhead

See the following steps to replace the gearhead or to change the cable position.

1. Removing the gearhead

Remove the hexagonal socket head screws assembling the motor and gearhead and detach the motor from the gearhead.

• Assembly hexagonal socket head screw

Model	Screw size	Tightening torque [N·m (lb-in)]
BMU230 BMU460S	M2.6	0.4 (3.5)
BMU5120	M3	0.6 (5.3)

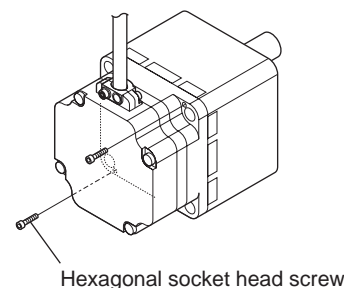

2. Installing the gearhead

Using the pilot sections of the motor and gearhead as guides, install the gearhead to the motor and tighten the hexagonal socket head screws.

Confirm that no gaps remain between the motor flange surface and the end face of the gearhead pilot section.

At this time, the motor cable position can be changed to a desired 90° direction.

When installing the gearhead, slowly rotate it clockwise/ counterclockwise to prevent the pinion of the motor output shaft from contacting the side panel or gear of the gearhead.

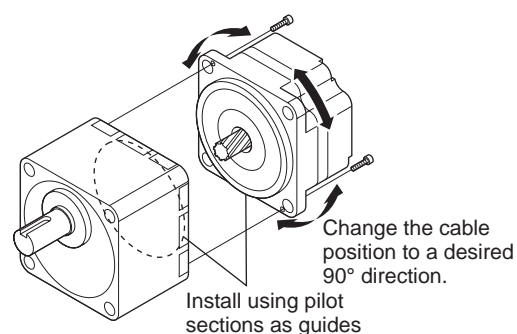

Note

- Do not forcibly assemble the motor and gearhead. Also, do not let metal objects or other foreign matter enter the gearhead. The pinion of the motor output shaft or gear may be damaged, resulting in noise or shorter service life.
- Do not allow dust to attach to the pilot sections of the motor and gearhead. Also, assemble the motor and gearhead carefully by not pinching the O-ring at the motor pilot section. If the O-ring is crushed or severed, grease may leak from the gearhead.
- The hexagonal socket head screws assembling the motor and gearhead are used to attach the motor and gearhead temporarily. When installing the motor/gearhead assembly, be sure to use the supplied hexagonal socket head screws.

■ Installing the round shaft type

Secure the motor with hexagonal socket head screws (not supplied) through the four mounting holes provided.

Do not leave a gap between the motor and mounting plate.

Install the motor to a mounting plate of the following size or larger, so that the motor case temperature will not exceed 90 °C (194 °F).

Model	Size of mounting plate [mm (in.)]	Thickness	Material
BMU230	115×115 (4.53×4.53)	5 mm (0.20 in.)	Aluminum
BMU260	135×135 (5.31×5.31)		
BMU5120	165×165 (6.50×6.50)		

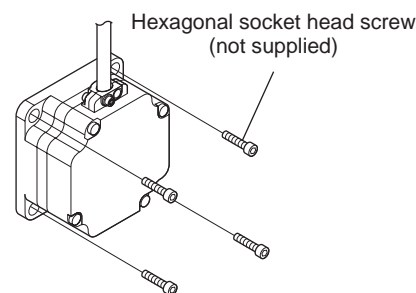

• Applicable mounting screw

Model	Screw size	Tightening torque [N·m (lb-in)]
BMU230 BMU260	M4	1.8 (15.9)
BMU5120	M8	15.5 (137)

• Mounting hole dimensions

[Unit: mm (in.)]

Model	ØA	B	ØC *
BMU230 BMU260	70 (2.76)	49.50 (1.949)	$54^{+0.030}_0$ (2.2160 ^{+0.0012})
BMU5120	104 (4.09)	73.54 (2.895)	$83^{+0.035}_0$ (3.2677 ^{+0.0014})

* ØC indicates the pilot diameter on the flange.

Note

Do not install the motor to the mounting hole diagonally or assemble the motor forcibly. Doing so may cause damage to the flange pilot section, thereby resulting in damage to the motor.

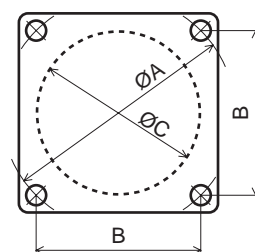

■ Installing a load

When installing a load on the motor (gearhead), pay attention to the following points.

- Align the centerline of the motor output shaft (gearhead output shaft) with the centerline of the load.
- A key slot is provided on the output shaft of each combination type parallel shaft gearhead. Form a key slot on the load side and secure the load using the supplied parallel key.

Note

- When coupling the motor (gearhead) with a load, pay attention to centering, belt tension, parallelism of pulleys, etc. Also, firmly secure the tightening screws of the coupling or pulleys.
- When installing a load, do not damage the motor output shaft (gearhead output shaft) or bearing. Forcing in the load by driving it with a hammer, etc., may break the bearing. Do not apply any excessive force to the output shaft.
- Do not modify or machine the motor (gearhead) output shaft. The bearing may be damaged or motor (gearhead) may break.

When using the output shaft end tapped hole of a gearhead (GFV4G, GFV5G only)

Use a tapped hole provided at the end of the output shaft as an auxiliary means for preventing the transfer mechanism from disengaging.

Gearhead model	Screw size	Effective depth
GFV4G	M5	10 mm (0.39 in.)
GFV5G	M6	12 mm (0.47 in.)

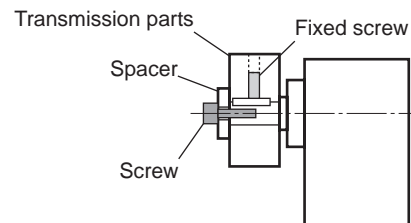

■ Permissible radial load and permissible axial load

The radial load and the axial load on the output shaft of the motor (gearhead) must be kept under the permissible values listed below.

Note

Failure due to fatigue may occur when the motor (gearhead) bearings and output shaft are subject to repeated loading by a radial or axial load that is in excess of the permissible limit.

• Combination type parallel shaft gearhead

Model	Gear ratio	Permissible radial load [N (lb.)] *		Permissible axial load [N (lb.)]
		Distance from tip of gearhead output shaft 10 mm (0.39 in.)	20 mm (0.79 in.)	
BMU230	5	100 (22) [90 (20)]	150 (33) [110 (24)]	40 (9)
	10 to 20	150 (33) [130 (29)]	200 (45) [170 (38)]	
	30 to 200	200 (45) [180 (40)]	300 (67) [230 (51)]	
BMU460S	5	200 (45) [180 (40)]	250 (56) [220 (49)]	100 (22)
	10 to 20	300 (67) [270 (60)]	350 (78) [330 (74)]	
	30 to 200	450 (101) [420 (94)]	550 (123) [500 (112)]	
BMU5120	5	300 (67) [230 (51)]	400 (90) [300 (67)]	150 (33)
	10 to 20	400 (90) [370 (83)]	500 (112) [430 (96)]	
	30 to 200	500 (112) [450 (101)]	650 (146) [550 (123)]	

* The values assume a rated speed of 3000 r/min or below. The values in [] are based on a rated speed of 4000 r/min.

• Round shaft type

Model	Permissible radial load [N (lb.)]		Permissible axial load [N (lb.)]
	Distance from output shaft end of the motor 10 mm (0.39 in.)	20 mm (0.79 in.)	
BMU230 BMU260	80 (18)	100 (22)	Not to exceed one-half the motor's dead weight *
BMU5120	150 (33)	170 (38)	

* Minimize the axial load. If an axial load must be applied, do not let it exceed one-half the motor's mass.

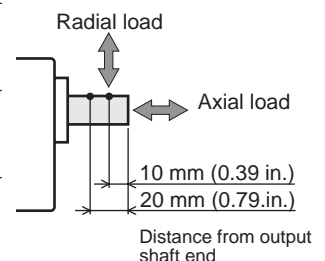

5.3 Installing the driver

The driver is designed so that heat is dissipated via air convection and conduction through the enclosure. There must be a clearance of at least 25 mm (0.98 in.) and 50 mm (1.97 in.) clearances in the horizontal and vertical directions, respectively, between the driver and enclosure or other equipment within the enclosure. When installing the driver, mount it turning the driver front panel to the front side or upper side.

- When turning the driver front panel to the front side

- When turning the driver front panel to the upper side

[Unit: mm (in.)]

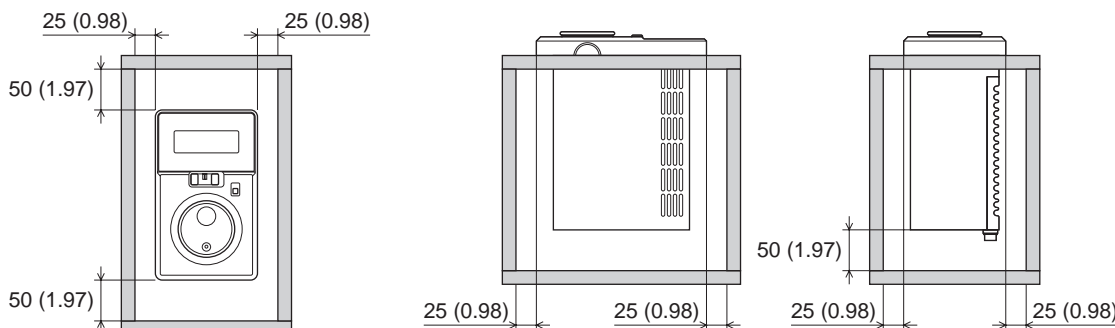

- Note**
- Do not install any equipment that generates a large amount of heat or noise near the driver.
 - If the ambient temperature of the driver exceeds 40 °C (104 °F), revise the ventilation condition or force-cool the area around the driver using a fan.

■ Installation method

Install the driver to a flat metal plate offering excellent vibration resistance. Remove the front panel of the driver and secure the two mounting holes using pan head machine screws and nuts (M4: not supplied). Tighten the screws until no gaps remain between the driver and mounting plate.

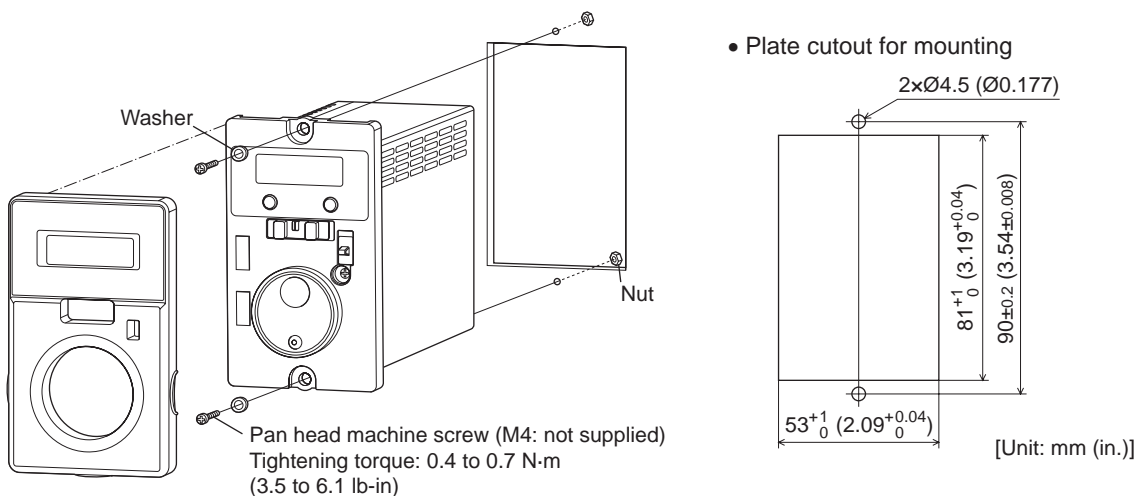

- Note**
- The space between the mounting hole section and front panel of the driver is 4.5 mm (0.18 in.). Therefore, the total height of the screw head and washer should be less than 4.5 mm (0.18 in.). The front panel cannot be installed if it is exceeded 4.5 mm (0.18 in.).
 - If the washer is used, use the washer which outer diameter is 8 mm (0.31 in.) or less.

[Removing and installing the front panel]

Installing

Install the front panel after placing on the upper side of the driver front face.

Removing

Remove the front panel having the under side.

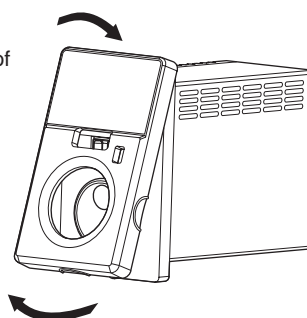

6 Connection

This chapter explains how to connect the driver and motor, I/O signals, and power supply, as well as the grounding method.

6.1 Connecting the power supply

Connect the power cable to the CN1 on the driver.

The power cable is not included. It is provided as an accessory (sold separately). (p.34)

Input power supply	Connecting method
Single-phase 100-120 V	Connect the live side to terminal L, and the neutral side to terminal N.
Single-phase 200-240 V	Connect the live side to terminal L1, and the neutral side to terminal L2.
Three-phase 200-240 V	Connect the R, S and T phase lines to the L1, L2 and L3 terminals, respectively.

• Single-phase 100-120 V

• Single-phase 200-240 V

• Three-phase 200-240 V

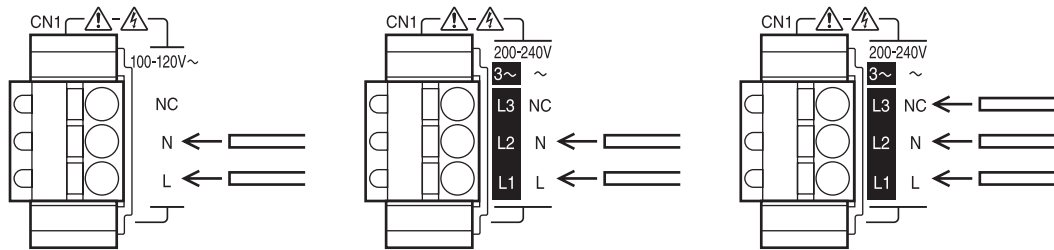

Connector model: FKC2,5/3-ST-5,08-RF (PHOENIX CONTACT GmbH & Co. KG)

■ Applicable lead wire

- Lead wire size: AWG18 to 14 (0.75 to 2.0 mm²)
- Length of the insulation cover which can be peeled: 10 mm (0.39 in.)
- Conductive material: Use only copper wire.

If crimp terminals are used, select the following terminals.

Manufacturer	PHOENIX CONTACT GmbH & Co. KG	
Model	Al 0.75-10	Conductor cross-sectional area: 0.65 to 0.82 mm ² (AWG18)
	Al 1-10	Conductor cross-sectional area: 0.82 to 1.2 mm ² (AWG18)
	Al 1.5-10	Conductor cross-sectional area: 1.25 to 1.8 mm ² (AWG16)
	Al 2.5 10	Conductor cross-sectional area: 2.0 to 3.0 mm ² (AWG14)

■ Circuit breaker

Be sure to connect a circuit breaker to the power line of the driver to protect the primary circuit.

Rated current of protective device: Single-phase input 10 A, three-phase input 5 A

Circuit breaker: Mitsubishi Electric Corporation NF30

6.2 Connecting the motor

Connect the motor power connector to CN2, and the motor signal connector to CN3 on the driver. Check the pin assignment on p.34.

Use a connection cable (supplied or accessory) when extending the wiring distance between the motor and driver.

Connection can be extended to a maximum of 10.5 m (34.4 ft.).

Note Ensure that the connector plugged in securely. Insecure connections may cause malfunction or damage to the motor or driver.

6.3 Grounding

■ Grounding the motor

Connect the Protective Earth Terminal on the motor to the ground near the motor. Minimize the wiring length of the ground cable.

Ground terminal

- Applicable crimp terminal:
Round crimp terminal with insulation cover
- Thread size of terminal: M4
- Tightening torque: 1.2 N·m (10.6 lb-in)
- Applicable lead wire: AWG18 to 14 (0.75 to 2.0 mm²)

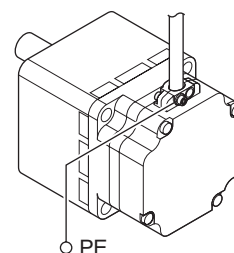
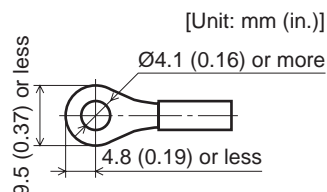

■ Grounding the driver

Two Protective Earth Terminals are provided on the driver. Ground either of the two Protective Earth Terminals near the driver. You can ground either of the two Protective Earth Terminals. The terminal that is not grounded is used as a service terminal. Use the service terminal according to your specific need, such as connecting it to the motor in order to ground the motor. Do not share the Protective Earth Terminal with a welder or any other power equipment.

Ground terminal

- Applicable crimp terminal:
Round crimp terminal with insulation cover
- Thread size of terminal: M4
- Tightening torque: 1.2 N·m (10.6 lb-in)
- Applicable lead wire: AWG18 to 14 (0.75 to 2.0 mm²)

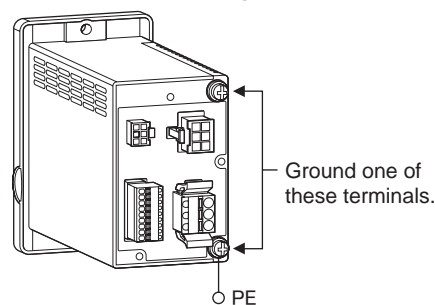

6.4 Connecting the I/O signals

Connect the I/O signals to CN4 on the driver.

- Applicable lead wire: AWG26 to 20 (0.14 to 0.5 mm²)
- Length of the insulation cover which can be peeled: 8 mm (0.31 in.)

If crimp terminals are used, select the following terminals.

Manufacturer	PHOENIX CONTACT GmbH & Co. KG	
Model	A 0.25-7	Conductor cross-sectional area: 0.14 to 0.34 mm ² (AWG24)
	A 0.34-7	Conductor cross-sectional area: 0.14 to 0.34 mm ² (AWG22)
	A 0.5-8	Conductor cross-sectional area: 0.40 to 0.65 mm ² (AWG20)

■ CN4 pin assignment

Pin No.	Terminal	Signal name	Description
9	C0	IN-COM0	Input signal common
8	X0	FWD *	The motor rotates in the forward direction.
7	X1	REV *	The motor rotates in the reverse direction.
6	X2	M0 *	Select the operation data.
5	C1	IN-COM1	Input signal common (0 V)
4	Y0+	SPEED-OUT *	30 pulses are output with each revolution of the motor output shaft.
3	Y0-		
2	Y1+	ALARM-OUT1 *	This signal turns OFF when an alarm generates (normally closed).
1	Y1-		

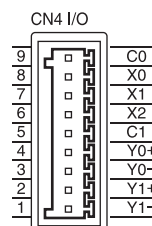

* Factory setting. You can change the assignments of I/O signals by setting parameters. Refer to p.26 for details.

Connector model: FK-MC0,5/9-ST-2,5 (PHOENIX CONTACT GmbH & Co. KG)

■ Input signal circuit

All input signals of the driver are photocoupler inputs. Use these signals by the internal power supply (+5 VDC) or external power supply. When using the external power supply, both sink input logic and source input logic can be used by changing the wiring.

Usable external power supply: 24 VDC -15% to +20%, 100 mA or more

■ Output signal circuit

The driver outputs signals are photocoupler/open-collector output. The ON voltage of the output circuit is max. 1.5 V. When driving each element using the output signal circuit, give consideration to this ON voltage. External power supply: 4.5 to 30 VDC, 100 mA or less (For the SPEED-OUT output, supply at least 5 mA of current.)

Note When connecting a relay (inductive load), etc., to detect alarm outputs, use a relay with built-in flywheel diode, or provide a fly-back voltage control measure based on diode, etc., for the inductive load.

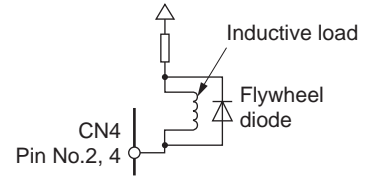

■ Using a external control equipment with a built-in clamp diode

If a external control equipment with a built-in clamp diode is used, a leakage path may form and cause the motor to operate even when the external control equipment power is off, as long as the driver power is on. Since the power capacity of the controller is different from that of the driver, the motor may operate when the external control equipment and driver powers are turned on or off simultaneously.

When powering down, turn off the driver power first, followed by the external control equipment power.

When powering up, turn on the external control equipment power first, followed by the driver power.

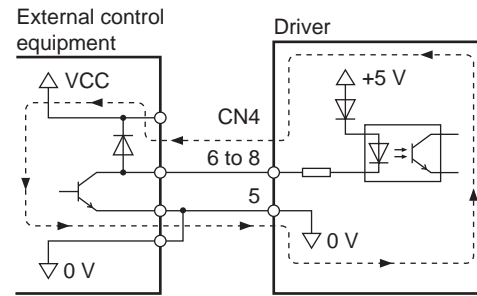

6.5 Connection example

The I/O signal in the brackets [] is the assignment at the time of shipment.

Note Connect a current-limiting resistor R according to the power supply voltage if the current flowing through the output signal exceeds 100 mA.

■ Sink logic: Using the built-in power supply

This is a connection example when the motor is operated using contact switches such as switches and relays. (Single-phase 100-120 VAC)

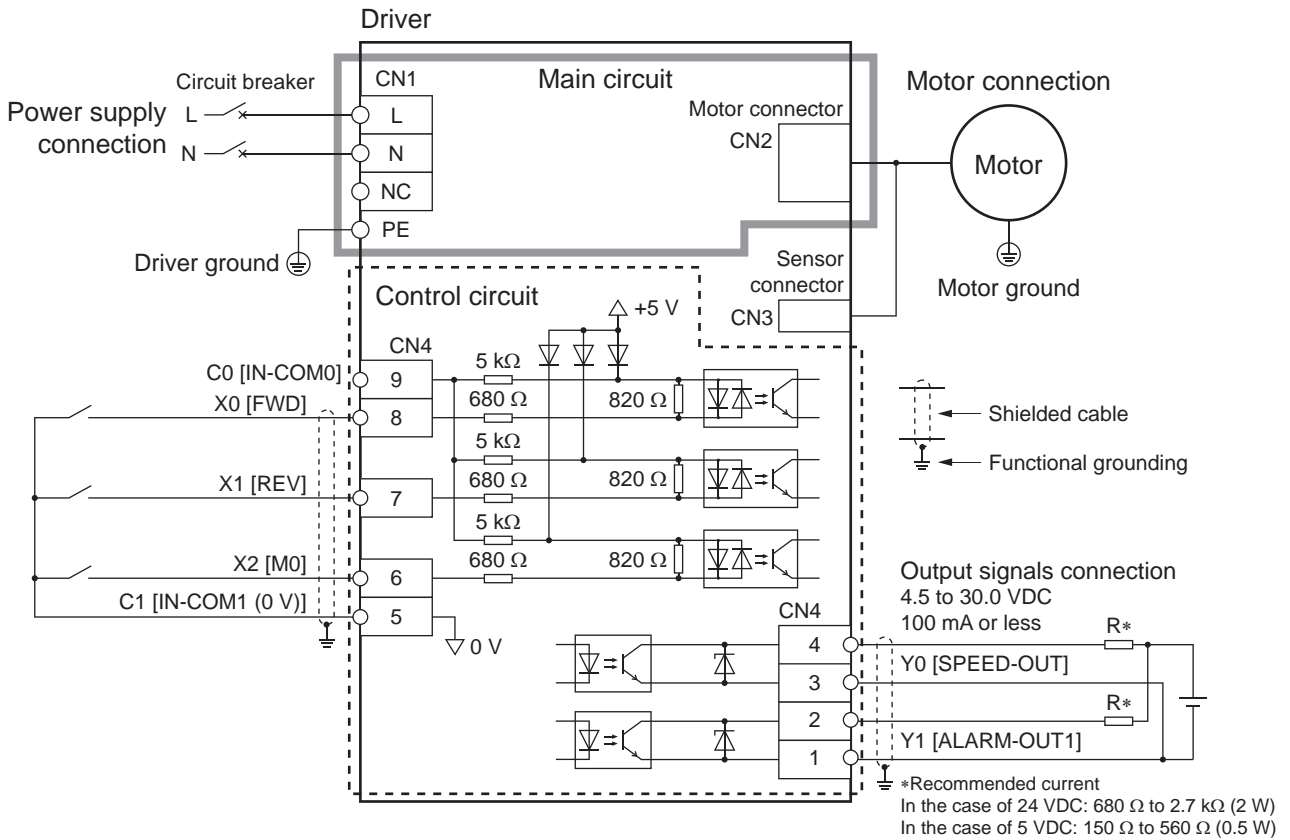

■ Sink logic: Using the external power supply

This is a connection example when the motor is operated using a transistor output type programmable controller. (Single-phase 100-120 VAC)

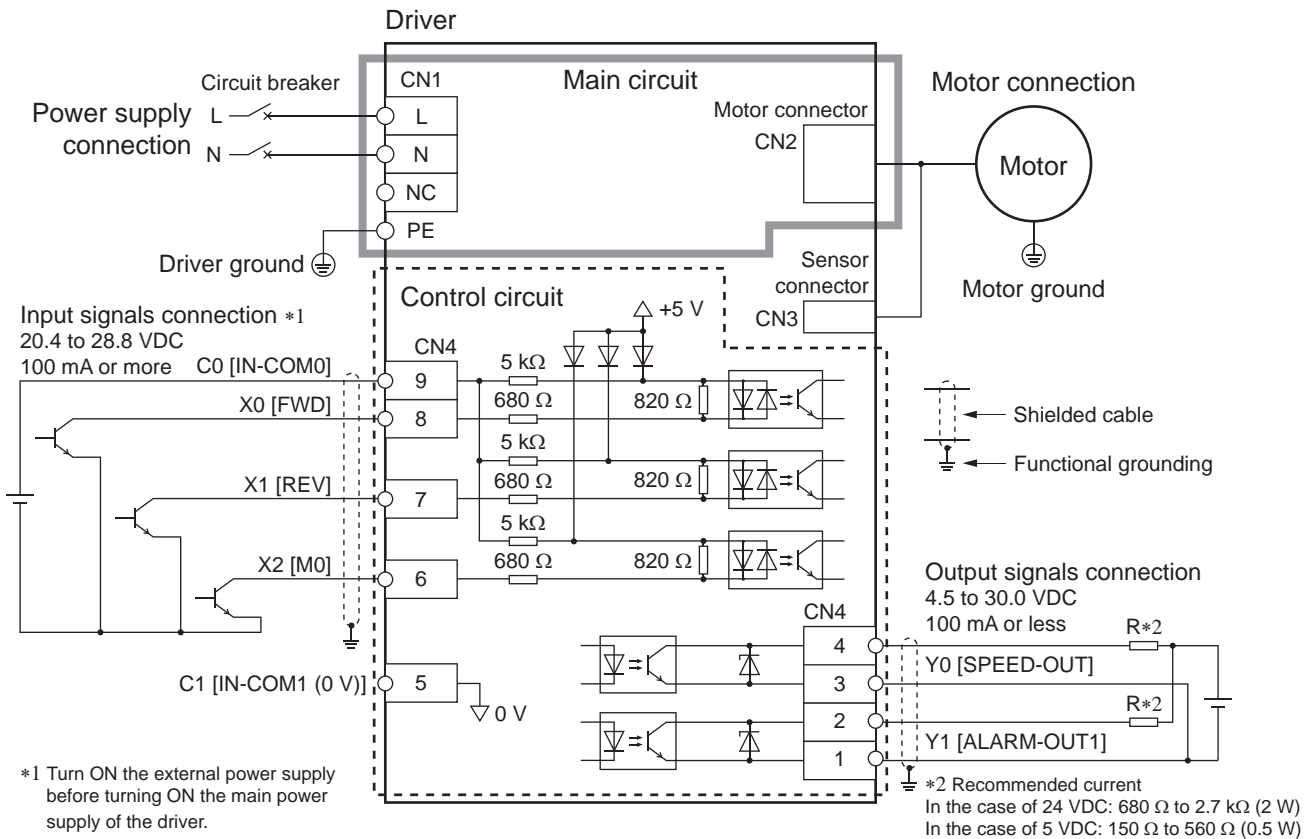

■ Source logic: Using the external power supply

This is a connection example when the motor is operated using a transistor output type programmable controller. (Single-phase 100-120 VAC)

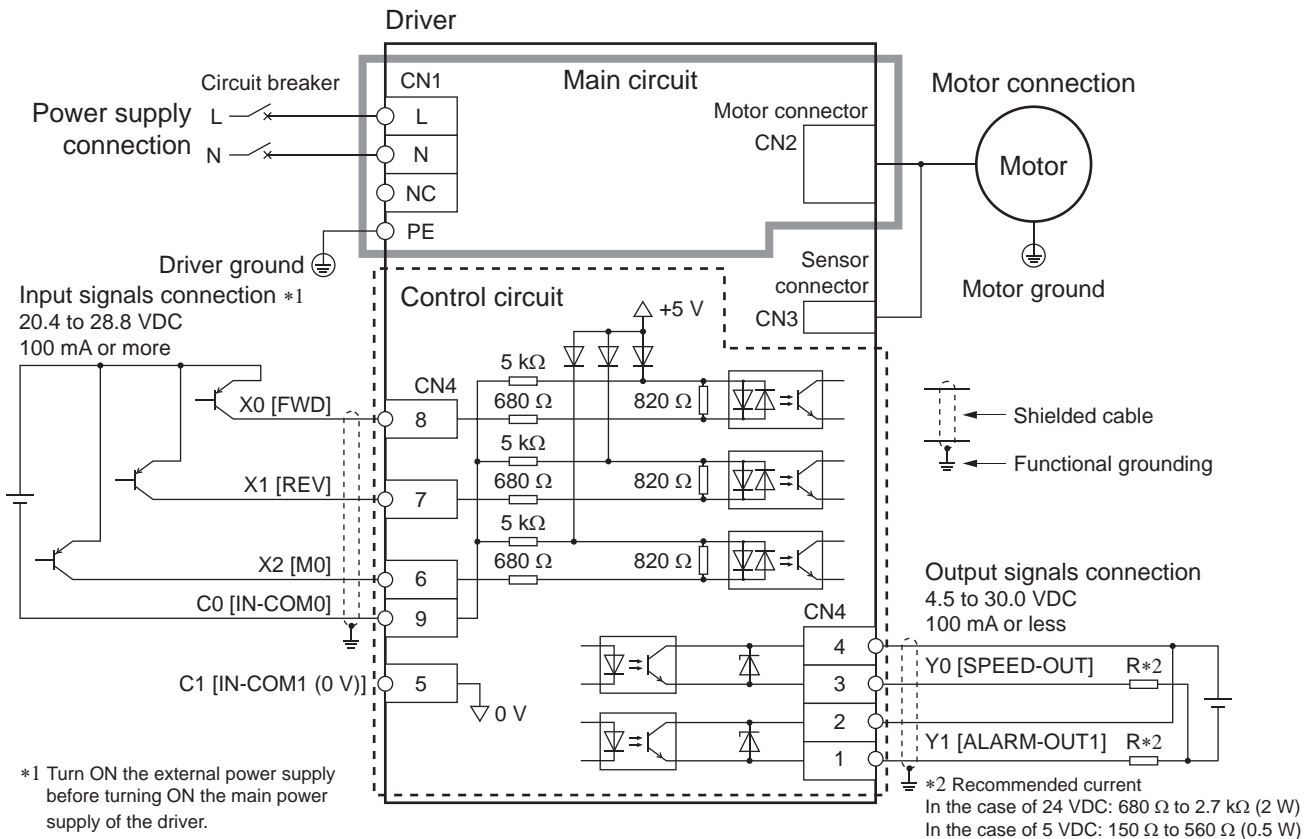

7 Functions

7.1 Functions list

The following functions are available for this product.

Functions	Description	Operation mode	Reference page
Display	Rotation speed	Monitor	p.23
	Load factor applied to the motor		
	Operation data number corresponding to the present operation		
	An alarm function is displayed using the alarm code.		p.23 p.29
	Alarm records are displayed.		p.23 p.31
	A warning function is displayed using the warning code.		
Warning records are displayed.			
Checking I/O signals	Checks whether a signal is input or output.		p.23
Setting the rotation speed	Sets the motor rotation speed using the setting dial.	Data	p.9
	Sets the motor rotation speed in the operation data.		p.24
Setting the acceleration time and deceleration time	Sets using the acceleration/deceleration time potentiometer.		
	Sets in the operation data.		
Operation lock function	Disables an operation with the setting dial so that the set data cannot be changed.	–	p.25
Operation using external signals	Operates by inputting signals externally.		p.25
Limiting the setting range of the rotation speed	Sets the upper limit and lower limit of the rotation speed.		p.28
Slight position-keeping	The load position can be kept at motor standstill.		
Speed display	Displays by converting the motor rotation speed into the speed of the gearhead output shaft.	Parameter	p.23
	Displays by converting the motor rotation speed into the increasing rotation speed.		
	Displays by converting the motor rotation speed into the transfer speed of the conveyor drive.		
Initial display at power ON	Changes the display item when turning on the power.		p.22
Assigned function for I/O signals	Changes the functions assigned to the input signals (3 input signals).		p.26
	Changes the functions assigned to the output signals (2 output signals).		
Data initialization	Restores the operation data to the factory setting (initial value).		p.20 p.24
	Restores the parameter setting to the factory setting (initial value).		p.20 p.22

7.2 Transition of display on the driver

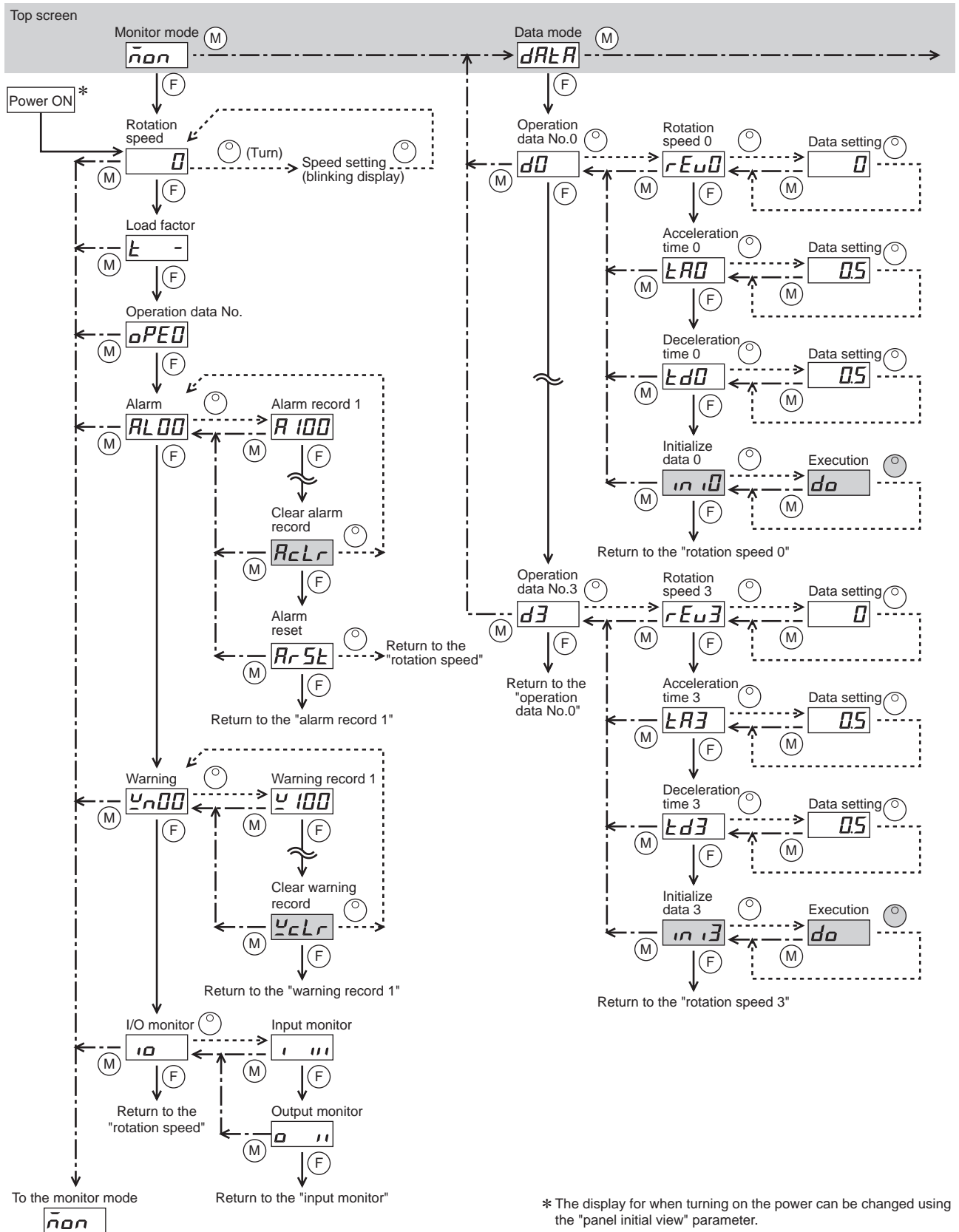

When the front panel is removed ■ How to use screen transitions

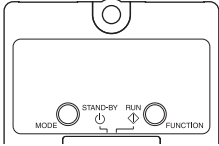

- : Press the setting dial. The value changes with turning the setting dial.
- : It cannot be performed while operating. "Err" was displayed.
- (M) : MODE key
- (F) : FUNCTION key
- : If operations are limited by the lock function, the screen in gray is not shown.

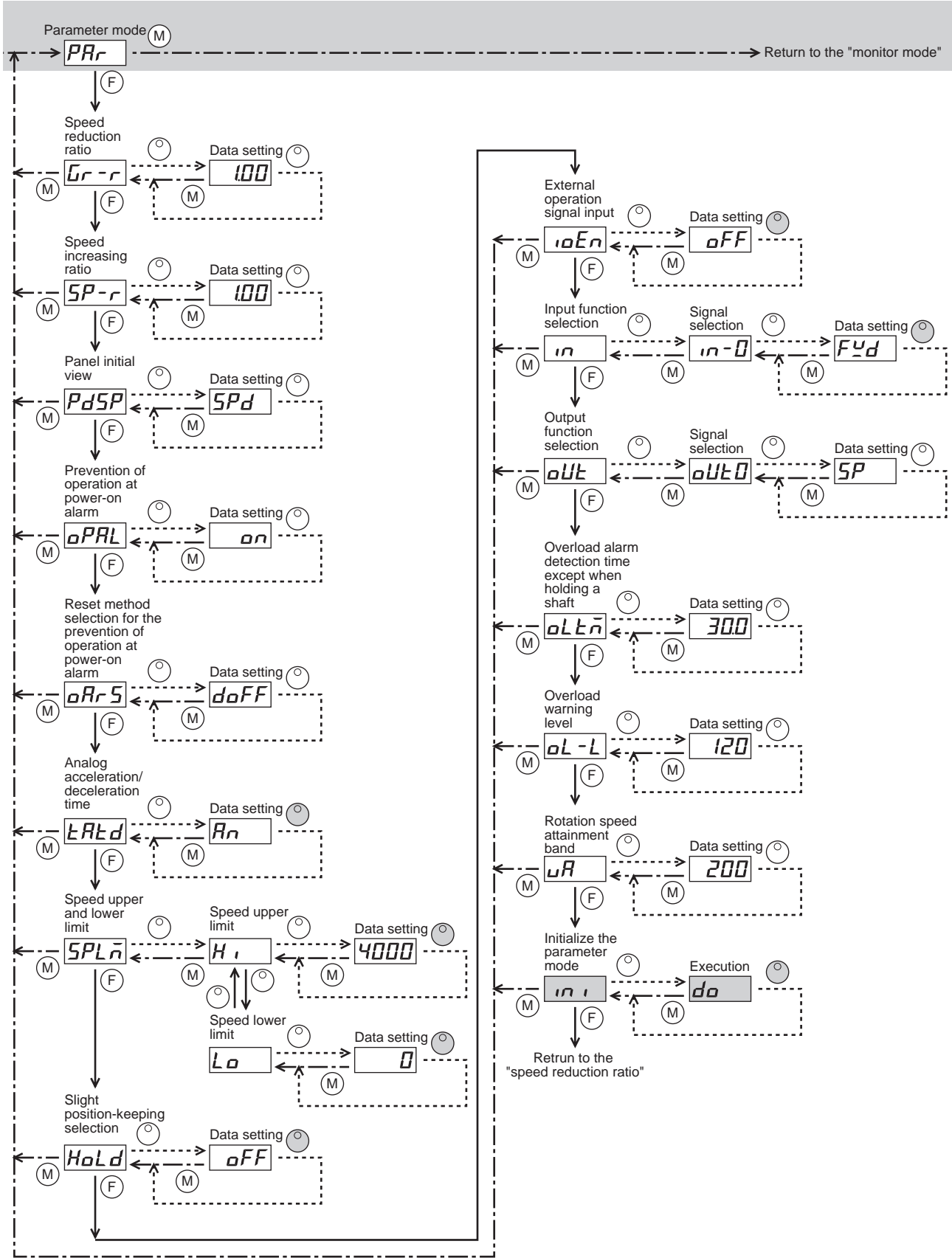

7.3 Parameter list

Operation mode: Parameter mode

Item	Display	Description	Setting range	Factory setting
Speed reduction ratio	<i>Gr-r</i>	Sets the speed reduction ratio relative to the rotation speed of the motor output shaft. Displays the speed calculated based on the speed reduction ratio on the monitor mode. If the speed reduction ratio for the conveyor is calculated and input, the conveyor transfer speed can also be displayed.	1.00 to 9999	1.00
Speed increasing ratio	<i>SP-r</i>	When increasing the motor rotation speed using the external mechanism and others, the converted speed can be displayed.	1.00 to 2.00	1.00
Panel initial view	<i>PdSP</i>	After the power is turned on, the item displayed on the monitor mode can be changed.	<i>SPd</i> Rotation speed (r/min) <i>Er%</i> Load factor (%) <i>d-no</i> Operation data No.0	<i>SPd</i>
Prevention of operation at power-on alarm	<i>oPRL</i>	Sets whether to enable or disable the "prevention of operation at power-on alarm."	<i>oFF</i> Disable <i>on</i> Enable	<i>on</i>
Reset method selection for the prevention of operation at power-on alarm	<i>oArS</i>	Selects how to reset the prevention of operation at power-on alarm.	<i>doFF</i> Resets by turning the FWD or REV signal OFF or by setting the operation switch to the STAND-BY side. <i>ArSt</i> Resets using the ALARM-RESET signal or the alarm reset "ArSt" on the monitor mode.	<i>doFF</i>
Analog acceleration/ deceleration time	<i>tAtd</i>	Changes the setting method of acceleration/ deceleration time.	<i>An</i> Using the acceleration/ deceleration time potentiometer (analog) <i>dIG</i> Using the operation data (digital)	<i>An</i>
Speed upper limit	<i>Hi</i>	Sets the upper limit of the rotation speed.	0, 50 to 4000	4000
Speed lower limit	<i>Lo</i>	Sets the lower limit of the rotation speed.		0
Slight position-keeping selection	<i>HoLd</i>	The load position can be kept at motor standstill.	<i>oFF</i> Disable <i>on</i> Enable	<i>oFF</i>
External operation signal input	<i>ioEn</i>	Operates the motor by the external signals (FWD or REV).	<i>oFF</i> Disable <i>on</i> Enable	<i>oFF</i>
X0 input function selection	<i>in-0</i>	Assigns the input signals to the external input terminals.	<i>----</i> Not used <i>Fwd</i> FWD <i>rEu</i> REV <i>n0</i> M0 <i>n1</i> M1	<i>Fwd</i>
X1 input function selection	<i>in-1</i>		<i>ArSt</i> ALARM-RESET <i>E-Er</i> EXT-ERROR <i>H-Fr</i> H-FREE	<i>rEu</i>
X2 input function selection	<i>in-2</i>		<i>----</i> Not used <i>AL-1</i> ALARM OUT1 <i>SP</i> SPEED-OUT <i>AL-2</i> ALARM-OUT2 <i>nouE</i> MOVE <i>uA</i> VA <i>uNG</i> WNG	<i>n0</i>
Y0 output function selection	<i>oUt0</i>	Assigns the output signals to the external output terminals.	<i>AL-1</i> ALARM OUT1 <i>SP</i> SPEED-OUT <i>AL-2</i> ALARM-OUT2 <i>nouE</i> MOVE <i>uA</i> VA <i>uNG</i> WNG	<i>SP</i>
Y1 output function selection	<i>oUt1</i>		<i>AL-1</i>	
Overload alarm detection time except when holding a shaft	<i>oLtn</i>	Sets the time to output the alarm after detecting the overload condition when a load up to the limited duty region exceeding the continuous duty region was applied.	0.1 to 60.0 s	30.0
Overload warning level	<i>oL-L</i>	Sets the detection level (load factor) for the overload warning function based on the rated current being 100%.	50 to 120%	120
Rotation speed attainment band	<i>uA</i>	Sets the band within which the rotation speed of the motor is deemed to have reached the set value.	0 to 400 r/min	200
Initialize the parameter mode	<i>ini</i>	Restores the value set in the parameter mode to the factory setting.	-	-

Note

- Do not turn off the motor power while the initialization is still in progress (= while the display is blinking). Doing so may damage the data.
- When setting the speed increasing ratio to 1.00, the speed reduction ratio will be effective. When setting the speed increasing ratio to other than 1.00, the speed increasing ratio will be effective.
- When setting a longer time in the "overload alarm detection time except when holding a shaft" parameter, an overload status may continue. Repeating this condition may result in shorter service life of the motor and gearhead.
- If a load exceeding the limited duty region was applied, the "overload alarm detection time except when holding a shaft" is maximum 5 seconds.

7.4 Items displayed on the driver

Operation mode: Monitor mode

Item	Display	Description
Rotation speed		<ul style="list-style-type: none"> • Monitors the rotation speed of the motor. • Monitors the rotation speed of the gear output shaft or conveyor transfer speed when the "speed reduction ratio" parameter is set. • When the "speed increasing ratio" parameter is set, the rotation speed being increased by the external mechanism is displayed.
Load factor		Monitors the current load factor based on the rated torque being 100%.(40 to 200%) This is not the permissible torque of the gearhead. " H" is displayed while the slight position-keeping is functioned.
Operation data No.		Monitors the operation data No. currently selected.
Alarm		When an alarm generates, the alarm code is displayed. You can also reset alarms or check and clear alarm records. Refer to p.29 for alarm type.
Warning		When a warning generates, the warning code is displayed. You can also check and clear warning records. Refer to p.31 for warning type.
I/O monitor		<p>You can check the ON/OFF status of each I/O signal of the driver. If the signal is ON, the corresponding digit is lit. If the signal is OFF, the digit is unlit.</p> <div style="display: flex; justify-content: space-around;"> <div style="text-align: center;"> <p>Input signals</p> </div> <div style="text-align: center;"> <p>Output signals</p> </div> </div>

■ Display of the rotation speed

- Displayed digit number when setting the speed reduction ratio or speed increasing ratio

Since the number of significant figures for the integer part is changed if the speed reduction ratio or speed increasing ratio is set, the digit number displayed on the panel will also be changed.

Setting value for the speed reduction ratio and speed increasing ratio	Display on the monitor mode
1.00 to 9.99	0 to 9999
10.0 to 99.9	0.0 to 999.9
100 to 999	0.00 to 99.99
1000 or more	0.000 to 9.999

- Display the conveyor transfer speed

To display the conveyor transfer speed, calculate the conveyor speed reduction ratio by using the formula below and set to the "speed reduction ratio" parameter.

$$\text{Conveyor speed reduction ratio} = \frac{1}{\text{Feed rate per motor revolution}} = \frac{\text{Gearhead gear ratio}}{\text{Pulley diameter [m]} \times \pi}$$

When the calculated conveyor speed reduction ratio is used, the conveyor transfer speed is converted as follows:

$$\text{Conveyor transfer speed [m/min]} = \frac{\text{Motor output shaft rotation speed [r/min]}}{\text{Conveyor speed reduction ratio}}$$

A calculation example is shown on the next page.

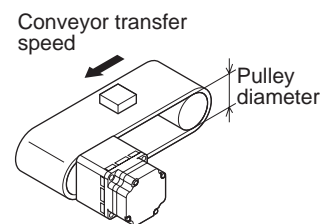

Example: The pulley diameter is 0.1 m and gear ratio of the gear head is 20

$$\text{Conveyor speed reduction ratio} = \frac{\text{Gearhead gear ratio}}{\text{Pulley diameter [m]} \times \pi} = \frac{20}{0.1 \text{ [m]} \times \pi} \cong 63.7$$

From the conversion formula, the conveyor speed reduction ratio is calculated as 63.7 in this example. If the speed reduction ratio is 63.7 and rotation speed of the motor is 1300 r/min, the conveyor transfer speed is converted as follows:

$$\text{Conveyor transfer speed [m/min]} = \frac{1300}{63.7} \cong 20.4$$

Accordingly, "20.4" is shown on the panel.

7.5 Setting the operation data

Operation mode: Data mode

The acceleration time/deceleration time set in the operation data is the time to reach the target speed from the current speed.

	Item	Display	Initial value	Factory setting
Operation data No.0 to No.3	Rotation speed	<i>rEu</i>	0, or 50 to 4000 r/min	0
	Acceleration time	<i>tA</i>	0.0 to 15.0 sec	0.5
	Deceleration time	<i>tD</i>		
	Initialize	<i>ini</i>	Restores the operation data to the factory setting.	–

■ Setting the acceleration/deceleration time with digital setting

Select the digital setting in the "analog acceleration/deceleration time" parameter to operate the motor with the acceleration/deceleration time set in the operation data. Refer to p.22 for details.

7.6 Setting the acceleration time and deceleration time

Setting range: 0.1 to 15.0 sec (factory setting: 0.1 sec)

Remove the front panel and adjust the acceleration/deceleration time using the acceleration/deceleration time potentiometer. The acceleration time and deceleration time are same value.

The acceleration time is set as the time needed for the motor to reach the rated rotation speed (3000 r/min) from the standstill state.

The deceleration time is set as the time needed for the motor to stop from the rated rotation speed.

The actual acceleration/deceleration time vary depending on the conditions of use, load inertia, load torque, etc.

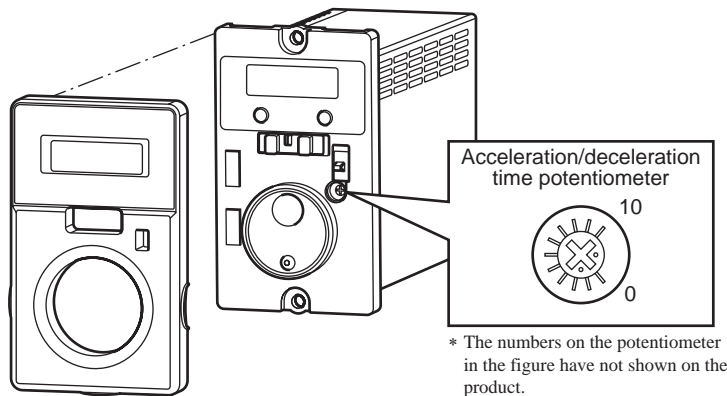

- Acceleration/deceleration time potentiometer characteristics (representative values)

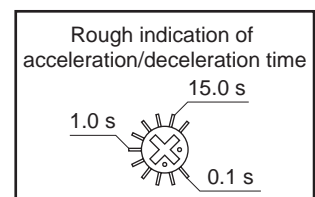
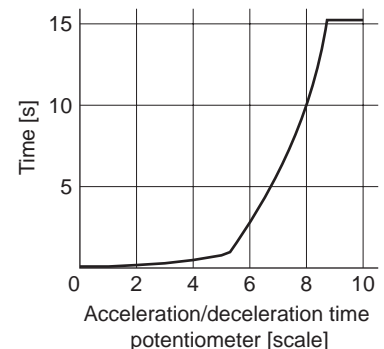

7.7 Disabling an operation with the setting dial

The lock function is used to prevent from changing the set speed or editing/erasing the set data using the setting dial on the driver front panel.

- **Setting the lock function**

In the top screen of each operation mode, press the [MODE] key for at least 5 seconds.

The display will show "LF" and the lock function will be enabled.

- **Canceling the lock function**

Again in the top screen of each operation mode, press the [MODE] key for at least 5 seconds.

The display will show "UnLF" and the lock function will be cancelled.

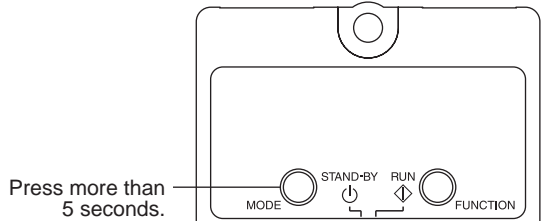

7.8 Operating with external signals

■ Operating method

See the followings for how to operate the motor using external signals.

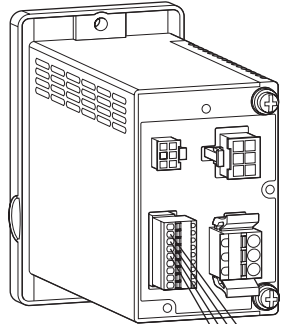

1. Connect the external signals in the right figure to the CN4.
2. Turn on the driver power.
3. Set the "external operation signal input" parameter to "ON (enable)." Refer to p.20 or p.22 for how to change the parameter.
4. Set the operation switch to the "RUN" side.
5. Turn the FWD input or REV input ON. The motor rotates. The motor decelerates and stops when turning the signal OFF.



- Pin No.8(X0): FWD
- Pin No.7(X1): REV
- Pin No.6(X2): M0
- Pin No.5(C1): IN-COM (10 V)

■ Rotation direction

The rotation direction varies depending on the status of the rotation direction switch and input signal. The rotation direction represents the direction when viewed from the motor output shaft side.

Rotation direction switch	Effective signal (signal being ON)	Rotation direction of motor output shaft
	FWD	CW
	REV	CCW
	FWD	CCW
	REV	CW

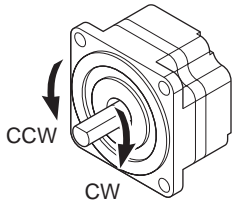

If the rotation direction switch is changed, the motor will decelerate to a stop and start rotating in the direction being switched.

Combination type parallel shaft gearhead

The rotation direction of the motor output shaft may vary from that of the gearhead output shaft depending on the gear ratio of the gearhead.

Gear ratio	Rotation direction of gearhead output shaft
5, 10, 15, 20, 200	Same as the motor output shaft
30, 50, 100	Opposite to the motor output shaft

■ Description of I/O signals

Signal	Terminal	Signal name	Description
Input	X0 X1 X2	FWD	The motor rotates when either of the FWD input or REV input is turned ON. If the FWD input and REV input are turned ON simultaneously, the motor stops instantaneously.
		REV	
		M0	This signal is used to select the operation data number. When turning OFF, the operation data No.0 is selected. See the following "speed selection."
		M1	
		ALARM-RESET	This signal is used to reset the present alarm when a protective function was activated. Refer to p.30 for timing chart.
		EXT-ERROR	When turning this signal OFF, an alarm generates and the motor stops instantaneously. Then "ALBE" will be shown on the display (normally closed).
		H-FREE	Reset the slight position-keeping.
Output	Y0 Y1	ALARM-OUT1	This signal is output when an alarm generates (normally closed).
		SPEED-OUT	30 pulses are output with each revolution of the motor output shaft synchronously with the motor operation. The pulse width of output pulse signals is 0.2 ms. You can use the SPEED-OUT output to calculate the motor speed. SPEED-OUT output frequency (Hz) = $\frac{1}{T}$ Rotation speed (r/min) = $\frac{\text{SPEED-OUT output frequency}}{30} \times 60$
		ALARM-OUT2	This signal is output when exceeding the overload warning level. Or this signal is output when an overload alarm generates (normally closed).
		MOVE	This signal is output while the motor is operating.
		VA	This signal is output when the motor rotation speed becomes equal the value set by the rotation speed attainment band parameter.
		WNG	This signal is output when a warning generates. (The motor will continue to operate.) When the warning is released, it will automatically turn OFF.

Note Do not assign the same input signal to multiple input terminals. When the same input signal is assigned to multiple input terminals, the function will be executed if any of the terminals becomes active.

■ Speed selection

Four operation data can be selected using the M0 and M1 inputs.

M0	M1	Operation data No.	Rotation speed	Acceleration time	Deceleration time
OFF	OFF	0	0	0	0
ON	OFF	1	1	1	1
OFF	ON	2	2	2	2
ON	ON	3	3	3	3

The settings of the acceleration time and deceleration time will be enabled by changing the "analog acceleration/ deceleration time" parameter. Refer to p.20 or p.22 for how to change the parameter.

■ Timing chart

The timing chart shown below is the case when the rotation direction switch is set to the "FWD" side.

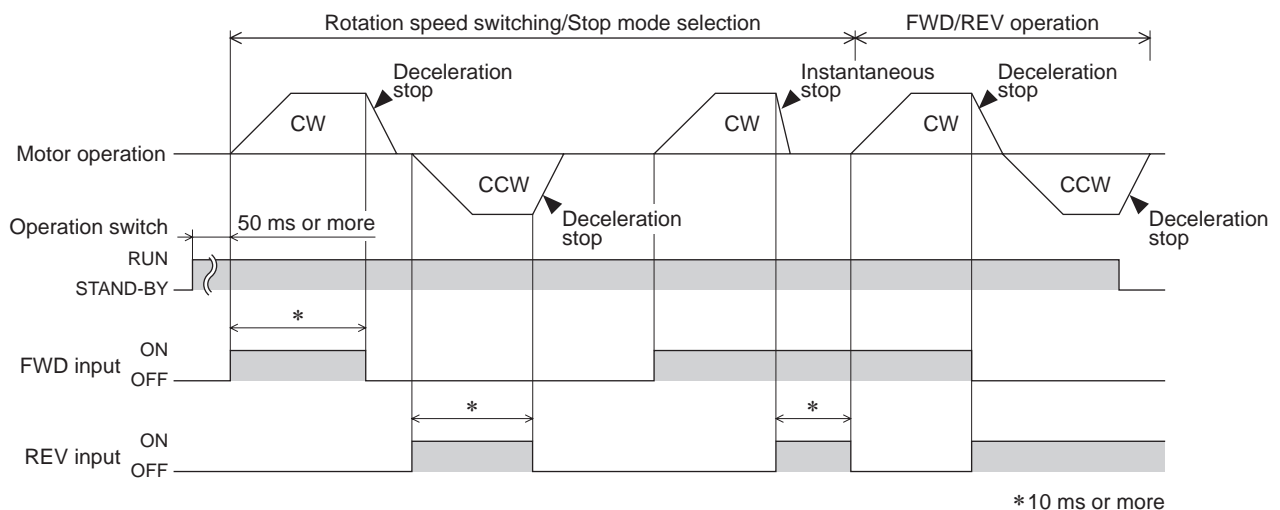

7.9 Operating with multiple speeds

The operation at a speed of two or more can be performed by switching the external input.

■ 2-speed operation

When setting data to the operation data No.0 and No.1, 2-speed operation can be performed by switching with the M0 input.

- **Operation example** This is an example for when performing operation with switching the rotation direction.

- [Operating condition]
- Rotation speed
Operation data No.0: 3000 r/min, operation data No.1: 1000 r/min
 - Rotation direction switch: "FWD" side

- [Operating method]
1. Perform the operating method No.1 to No.4 of "7.8 Operating with external signals" (p.25).
 2. Set the rotation speed in the operation data with the data mode.
Operation data No.0: 3000 r/min, operation data No.1: 1000 r/min
Refer to p.20 or p.24 for how to set the operation data.
 3. Turn the FWD input ON.
The motor rotates at 3000 r/min. (Operation data No.0)
 4. Turn the M0 input ON on the way in operation.
The motor rotation speed is changed to 1000 r/min, and the operation continues. (Operation data No.1)
 5. Turn the FWD input OFF and the REV input ON.
The motor decelerates to a stop, and the rotation direction is switched.
 6. Turn the M0 input OFF on the way in operation.
The motor rotation speed is changed to 3000 r/min, and the operation continues. (Operation data No.0)
 7. Turn the FWD input OFF.
The motor decelerates and stops.

[Timing chart]

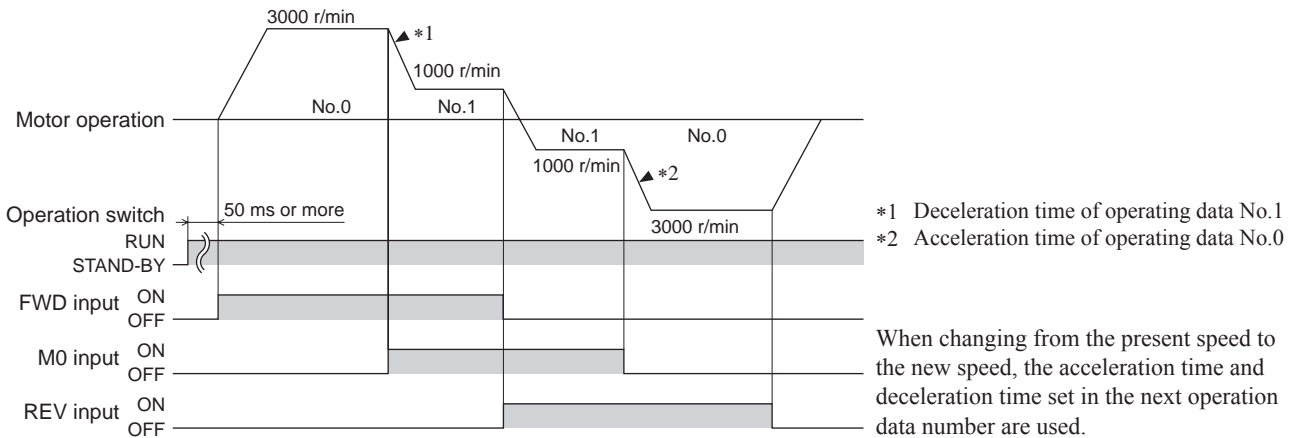

■ 4-speed operation

When performing 4-speed operation, assign the M1 input to the input signal terminal and set data to the operation data No.0 to No.3, then switch the speeds using the M0 and M1 inputs.

- **Operation example**

[Operating condition]

- Rotation speed
Operation data No.0: 3000 r/min, operation data No.1: 1000 r/min
Operation data No.2: 2000 r/min, operation data No.3: 500 r/min
- Rotation direction switch: "FWD" side

[Input signal]

Terminal name	Signal name
X0	FWD
X1	M0
X2	M1
C1	IN-COM1

[Timing chart]

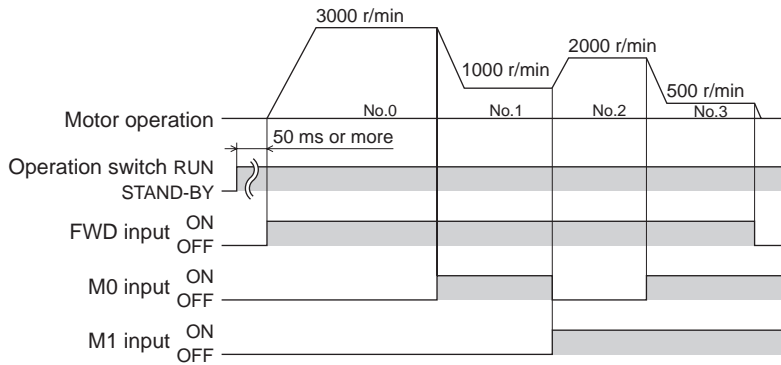

7.10 Limiting the setting range of the rotation speed

The setting range of the rotation speed is set to 0 to 4000 r/min at the time of shipment. This setting range can be changed to limit.

Setting range of the rotation speed

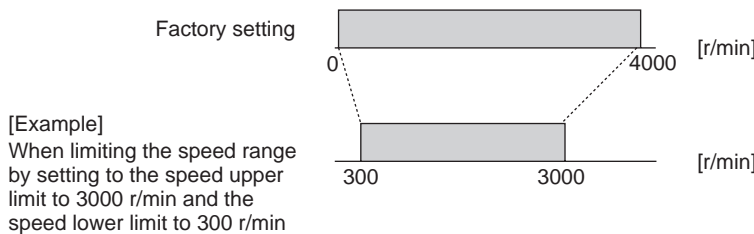

- Speed upper limit

Set the upper limit value of the rotation speed in the "speed upper limit" of the "speed upper and lower limit" parameter. The rotation speed exceeding the "speed upper limit" cannot be set in the rotation speed of the operation data. If the rotation speed exceeding the "speed upper limit" is already set in the operation data, the rotation speed set in the "speed upper limit" will be overwritten.

- Speed lower limit

Set the lower limit value of the rotation speed in the "speed lower limit" of the "speed upper and lower limit" parameter. The rotation speed lower than the "speed lower limit" cannot be set in the rotation speed of the operation data. If the rotation speed lower than the "speed lower limit" is already set in the operation data, the rotation speed set in the "speed lower limit" will be overwritten.

7.11 Holding a load at motor standstill

If the "slight position-keeping selection" parameter is set to ON (enable), the holding torque is somewhat generated when the motor stops (slight position-keeping torque).

The factory setting is OFF (disable). Refer to p.20 or p.22 for how to change the parameter.

- * Up to 50% of the rated torque is generated according to the angle variation of the motor output shaft (right figure). The position of a load exceeding 50% of the rated torque cannot be kept.
- * When the power supply to the driver is turned off, the holding torque is lost. This function cannot be used for keeping the load position in the event of a power outage.

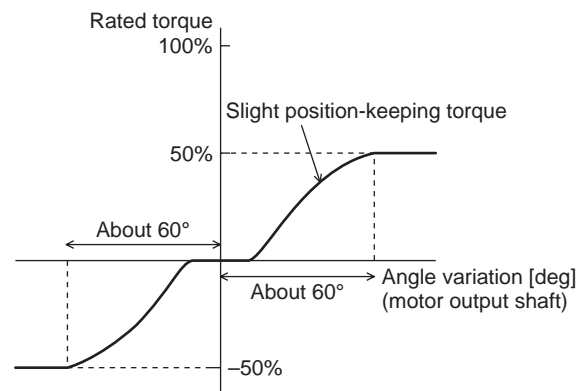

Slight position-keeping torque characteristic

8 Alarms and warnings

The driver provides alarms that are designed to protect the driver from overheating, poor connection, error in operation, etc. (protective functions), as well as warnings that are output before the corresponding alarms generate (warning functions).

8.1 Alarms

If a protective function is activated and an alarm is generated, the motor will coast to a stop, and then the holding power of the motor output shaft is lost. At the same time, the alarm code is displayed. The alarm type can be checked by the alarm code.

Note

- Cycle the power to reset the overcurrent and EEPROM error alarms. When cycling the power, turn off the power and wait for minimum 1 minute before doing so. If the product does not operate properly after the power is cycled, the internal circuit may be damaged. Contact your nearest Oriental Motor branch or sales office.
- The motor stops instantaneously at the time of external stop (AL6E). After the motor is stopped, the holding power of the motor output shaft is lost.

Alarm list

Alarm code	Alarm type	Cause	Remedial action	Alarm reset *1
<i>AL20</i>	Overcurrent	Excessive current has flown through the driver due to ground fault, etc.	Check the wiring between the driver and motor for damage.	Not possible
<i>AL21</i>	Main circuit overheat	The temperature inside the driver exceeded the alarm detection temperature.	<ul style="list-style-type: none"> • Review the ambient temperature. • Review the ventilation condition in the enclosure. 	
<i>AL22</i>	Overvoltage	<ul style="list-style-type: none"> • The power supply voltage exceeded approximately 120% of the rated voltage. • Vertical drive (gravitational operation) was performed or a load exceeding the permissible load inertia was driven. 	<ul style="list-style-type: none"> • Check the power supply voltage. • If this alarm occurs during operation, reduce the load or make the acceleration/ deceleration time longer. 	
<i>AL25</i>	Undervoltage	The power supply voltage became lower than approximately 60% of the rated voltage.	<ul style="list-style-type: none"> • Check the power supply voltage. • Check the wiring of the power supply cable. 	
<i>AL28</i>	Sensor error	The motor sensor signal line experienced an open circuit during operation, or the motor signal connector came off.	Check the wiring between the driver and motor.	
<i>AL30</i>	Overload	<ul style="list-style-type: none"> • A load exceeding the continuous duty region was applied to the motor for the time exceeded the value set in the "overload alarm detection time except when holding a shaft" parameter. *2 • The motor was started running under the state that the motor temperature was low. 	<ul style="list-style-type: none"> • Reduce the load. • Review the operation pattern such as acceleration/deceleration time. 	
<i>AL31</i>	Overspeed	The rotation speed of the motor output shaft exceeded approximately 4800 r/min.		
<i>AL41</i>	EEPROM error	<ul style="list-style-type: none"> • The stored data was damaged. • Data became no longer writable or readable. 	Initialize the parameters.	Not possible
<i>AL42</i>	Sensor error at power-on	The motor sensor signal line experienced an open circuit during operation, or the motor signal connector came off when turning on the power.	Check the wiring between the driver and motor.	
<i>AL46</i>	Prevention of operation at power-on *3	<p>When the "external operation signal input" parameter was set to disable, while the operation switch was set to the "RUN" side, the power was turned on again.</p> <p>When the "external operation signal input" parameter was set to enable, while the FWD input or REV input was turned ON, the power was turned on again.</p>	<p>Set the operation switch to the "STAND-BY" side from the "RUN" side.</p> <ul style="list-style-type: none"> • Set the operation switch to the "STAND-BY" side from the "RUN" side. • Turn the FWD input or REV input from ON to OFF. 	
<i>AL6E</i>	External stop *4	The EXT-ERROR input turned OFF.	Check the EXT-ERROR input.	

*1 When using the alarm reset on the monitor mode or resetting the alarm by assigning the ALARM-RESET input to the input terminal.

*2 If an operation was performed while applying a load exceeding the limited duty region, the alarm may generate even if the time is within the setting value of the "overload alarm detection time except when holding a shaft" parameter.

*3 This alarm is output when the "prevention of operation at power-on alarm" parameter is set to "Enable."

*4 This alarm is output when the EXT-ERROR is assigned to input terminal.

■ Alarm reset

Always reset an alarm after ensuring safety by removing the cause of the alarm and turning the operation signal OFF.

[How to reset the alarm]

- Turn the ALARM-RESET input to ON and then OFF. (The alarm will be reset at the OFF edge of the input.)
- Perform an alarm reset with the monitor mode.
- Turn off the power, wait for at least 1 minute, and then cycle the power.

When an alarm is reset, "AL00" is displayed for two seconds, then "0" is displayed.

Note

- If the motor does not operate properly after the power is cycled, internal circuit damage is suspected. Please contact your nearest Oriental Motor branch or sales office.
- Continuing the operation without removing the cause of the problem may cause malfunction of the equipment.

- Reset using the ALARM-RESET input

Turn the operation signal OFF and then turn ALARM-RESET input ON (keep it ON for 10 msec or more). The ALARM-RESET input is disabled while the operation signal is being ON. The figure shows an example for which the operation signal is the FWD input.

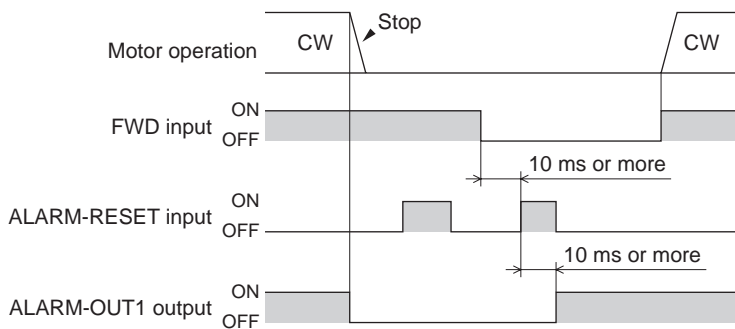

- Reset with the monitor mode

Set the operation switch to the "STAND-BY" side from the "RUN" side, and reset the alarm by the following steps.

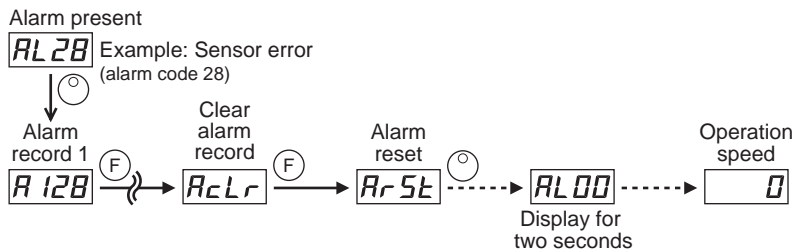

- When the present alarm is the prevention of operation at power-on alarm "AL46"

Set the operation switch to the "STAND-BY" side from the "RUN" side.

This is the factory setting. The method to reset the alarm can be changed. Refer to p.20 or p.22 for details.

■ Alarm records

Up to 9 generated alarms are saved in the non-volatile memory in order of the latest to oldest.

When clearing the alarm records, perform the alarm record clear on the monitor mode.

Note

- Do not turn off the driver power while an alarm records are being cleared (=while the display is blinking). Doing so may damage the data.

8.2 Warnings

When a warning generates, the warning code is displayed. The warning type can be checked by the warning code.

■ Warning list

Warning code	Warning type	Motor operation	Generation condition	Remedial action
$\underline{U}n21$	Main circuit overheat	Continue to operate	The temperature inside the driver exceeded the warning detection temperature.	<ul style="list-style-type: none"> • Review the ambient temperature. • Review the ventilation condition in the enclosure.
$\underline{U}n30$	Overload		A load exceeding the "overload warning level" parameter was applied to the motor.	Check the load condition.
$\underline{U}n6c$	Operation error	Stop	When the input terminal is ON, the operation signal was assigned using the "input function selection" parameter.	When assigning the operation signal, check that the input terminal to be assigned is turned OFF.

■ Warning records

Up to 9 generated warnings are saved in the RAM in order of the latest to oldest.

When clearing the warning records, perform the warning record clear on the monitor mode.

Note | The warning records will be cleared by turning off the driver power.

9 Inspection/Troubleshooting and remedial actions

9.1 Inspection

It is recommended that periodic inspections for the items listed below are conducted after each operation of the motor. If an abnormal condition is noted, discontinue any use and contact your nearest Oriental Motor sales office.

- Note**
- Perform the insulation resistance test or dielectric strength test separately on the motor and the driver. Performing the insulation resistance test or dielectric strength test with the motor and driver connected may result in damage to the product.
 - The driver uses semiconductor elements, so be extremely careful when handling them. Electrostatic discharge can damage the driver.

■ During inspection

- Are any of the motor (gearhead) mounting screws loose?
- Are there any abnormal noises in the motor bearings (ball bearings) or other moving parts?
- Are there any abnormal noises in the bearing (ball bearing) and gear meshing parts of the gearhead?
- Are the motor output shaft and load shaft out of alignment?
- Are there any scratches, signs of stress or loose driver connections in the cable?
- Are the openings in the driver blocked?
- Are any of the mounting screws or main power input unit of the driver loose?
- Are there any strange smells or appearances within the driver?

9.2 Troubleshooting and remedial actions

During motor operation, the motor or driver may fail to function properly due to an improper speed setting or wiring. When the motor cannot be operated correctly, refer to the contents provided in this section and take appropriate action. If the problem persists, contact your nearest office.

Phenomenon	Possible cause	Remedial action
The motor does not operate.	Connection error in the power supply.	Check the connections between the driver and power supply.
	The operation switch is set to the "STAND-BY" side.	Set the operation switch to the "RUN" side.
	When the "external operation signal input" parameter is set to disable, the FWD input or REV input is turned ON.	Set the "external operation signal input" parameter to enable after turning the input operation signal OFF.
	Both the FWD input and REV input are being OFF	Turn either of the FWD input or REV input ON.
	Both the FWD input and REV input are being ON.	
	An alarm is present.	A protective function is triggered and an alarm generates. Refer to p.29 and reset the alarm after removing the cause of the alarm.
The motor rotates in the direction opposite to the specified direction.	The FWD input and REV input are connected wrongly or otherwise not connected correctly.	Check the connection of the FWD input and REV input.
	The combination type parallel shaft gearhead is using a gear with a gear ratio of 30, 50 and 100.	When the gear ratio of the combination type parallel shaft gearhead is 30, 50 and 100, the rotating direction of the gear output shaft is opposite of the motor output shaft. Accordingly, reverse the FWD input and REV input operations.
	The rotation direction switch is set wrong.	Check the rotation direction switch.
The setting cannot be performed using the setting dial.	The lock function has been enabled.	Release the lock function.
The rotation speed cannot be increased.	The speed upper limit has been set.	Set the speed upper limit to 4000 r/min.
The rotation speed cannot be decreased.	The speed lower limit has been set.	Set the speed lower limit to 0 r/min.
<ul style="list-style-type: none"> • Motor operation is unstable. • Motor vibration is too great. 	The motor (gearhead) output shaft is not misaligned with the load shaft.	Check the coupling condition of the motor (gearhead) output shaft and load shaft.
	Effect of electrical noise.	Check the operation only with the motor, driver and other external equipment required for operation. If an effect of noise has been confirmed, implement the following countermeasures: <ul style="list-style-type: none"> · Move the unit farther away from noise generation sources. · Review the wiring. · Change the signal cables to a shielded type. · Install ferrite cores.

Note

- Check the alarm message when the alarm generates.
- I/O signals can be monitored with the monitor mode. Use to check the wiring condition of the I/O signals.

10 Accessories (sold separately)

■ Connection cable

This cable is used to extend the wiring distance between the driver and motor. Connection can be extended to a maximum of 10.5 m (34.4 ft.). Flexible connection cables are also available.

• Connection cable		• Flexible connection cable	
Length [m (ft.)]	Model	Length [m (ft.)]	Model
1 (3.3)	CC01BLE	1 (3.3)	CC01BLER
2 (6.6)	CC02BLE	2 (6.6)	CC02BLER
3 (9.8)	CC03BLE	3 (9.8)	CC03BLER
5 (16.4)	CC05BLE	5 (16.4)	CC05BLER
7 (23.0)	CC07BLE	7 (23.0)	CC07BLER
10 (32.8)	CC10BLE	10 (32.8)	CC10BLER

Connector pin assignments of motor cable

The following tables are the connector pin assignments of the motor cable that comes out of the motor.

• Motor power connector

Pin No.	Color	Lead wire
1	Blue	AWG18
2	–	–
3	–	Drain AWG24 or equivalent
4	Purple	AWG18
5	Gray	
6	–	–

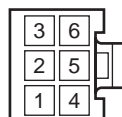

Housing: 5557-06R-210 (molex)
Terminal: 5556T (molex)

• Motor signal connector

Pin No.	Color	Lead wire
1	–	–
2	Green	AWG26
3	Yellow	
4	Brown	
5	Red	
6	Orange	–

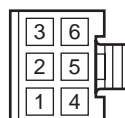

Housing: 43025-0600 (molex)
Terminal: 43030-0004 (molex)

■ Power supply cable

This cable is used to connect the driver to the power supply.

• For single-phase 100 VAC (with plug)		• For single-phase 100-120/200-240 VAC		• For three-phase 200-240 VAC	
Length [m (ft.)]	Model	Length [m (ft.)]	Model	Length [m (ft.)]	Model
1 (3.3)	CC01AC03P	1 (3.3)	CC01AC03N	1 (3.3)	CC01AC04N
2 (6.6)	CC02AC03P	2 (6.6)	CC02AC03N	2 (6.6)	CC02AC04N
3 (9.8)	CC03AC03P	3 (9.8)	CC03AC03N	3 (9.8)	CC03AC04N

These cables are not shielded cables. If conformance to the EMC Directive is required, refer to "11.2 Installing and wiring in compliance with EMC Directive" (p.36).

11 Reference

11.1 Standard and CE Marking

This product is recognized by UL. The CE Marking (Low Voltage Directive and EMC Directive) is affixed to the product in accordance with EN Standards.

The name of products certified to conform with relevant standards are represented by applicable unit model motor and driver part numbers.

■ UL Standards and CSA Standards

• Applicable Standards

	Applicable Standards	Certification Body	Standards File No.
Motor *	UL 1004-1 CSA C22.2 No.100	UL	E335369
Driver	UL 508C CSA C22.2 No.14		E171462

* Thermal class UL/CSA Standards: 105(A)

A temperature test has been conducted with a heatsink plate. The size, thickness and material of the heatsink plates are as below table.

Motor model	Size [mm (in.)]	Thickness [mm (in.)]	Material
BLM230	115×115 (4.53×4.53)	5 (0.20)	Aluminum
BLM260	135×135 (5.31×5.31)		
BLM460			
BLM5120	165×165 (6.50×6.50)		

■ Low Voltage Directive

- This product is designed and manufactured to be incorporated in equipment.
- This product cannot be used with cables normally used for IT equipment.
- Install the product within the enclosure in order to avoid contact with hands.
- Be sure to ground the Protective Earth Terminal of the motor and driver.
- Isolate the motor cable, power-supply cable and other drive cables from the signal cables (CN4) by means of double insulation.

• Applicable Standards

- Motor: EN 60034-1, EN 60034-5, EN 60664-1
- Driver: EN 61800-5-1

Installation conditions (EN Standard)

Motor *	Driver
For incorporating in equipment	For incorporating in equipment
Overvoltage category: II	Overvoltage category: II
Pollution degree: 2 (for IP20 rated motor) 3 (for IP65 rated motor)	Pollution degree: 2
Protection against electric shock: Class I	Protection against electric shock: Class I

* Thermal class EN Standards: 120(E)

■ EMC Directive

This product has received EMC compliance under the conditions specified in "Example of motor and driver installation and wiring" on p.37. The final level of conformance of your mechanical equipment to the EMC Directive will vary depending on the control system equipment used with the motor/driver, configuration of electrical parts, wiring, layout, hazard level, and the like. It therefore must be verified through conducting EMC measures on your mechanical equipment.

• Applicable Standards

EMI	Emission Tests	EN 61000-6-4, EN 61800-3 C3
	Harmonics Current Test	EN 61000-3-2
	Voltage Fluctuations Test	EN 61000-3-3
EMS	Immunity Tests	EN 61000-6-2, EN 61800-3 C3

This type of PDS is not intended to be used on a low-voltage public network which supplies domestic premises; radio frequency interference is expected if used on such a network.

■ Hazardous substances

The products do not contain the substances exceeding the restriction values of RoHS Directive (2011/65/EU).

■ Republic of Korea, Radio Waves Act.



한국전파법

Seller and user shall be noticed that this equipment is suitable for electromagnetic equipments for office work (Class A) and it can be used outside home.

이 기기는 업무용(A 급) 전자파적합기기로서 판매자 또는 사용자는 이 점을 주의하시기 바라며, 가정외의 지역에서 사용하는 것을 목적으로 합니다.

11.2 Installing and wiring in compliance with EMC Directive

This product has been designed and manufactured to be incorporated in equipment. The EMC Directive requires that your mechanical equipment in which the product is installed satisfies the applicable requirements.

The installation/wiring methods of the motor and driver explained here represent the basic methods that are effective in helping your mechanical equipment conform to the EMC Directive.

The final level of conformance of your mechanical equipment to the EMC Directive will vary depending on the control system equipment used with the motor, configuration of electrical parts, wiring, layout, hazard level, and the like. It therefore must be verified through conducting EMC measures on your mechanical equipment.

Without effective measures to suppress the electromagnetic interference (EMI) caused by the product in the surrounding control system equipment or the electromagnetic spectrum (EMS) generated by the product, the function of your mechanical equipment may be seriously affected. This product will conform to the EMC Directive if installed/wired using the methods specified below.

■ Connecting a mains filter

Install a mains filter which the customer provides, in the power line in order to prevent the noise generated within the driver from propagating outside via the AC input line. For mains filters, use the products as shown in the chart, or an equivalent.

Manufacturer	Single-phase 100-120 V Single-phase 200-240 V	Three-phase 200-240 V
SOSHIN ELECTRIC CO., LTD	HF2010A-UPF, NF2010A-UP	NFU3010C-Z1
Schaffner EMC	FN2070-10-06	FN251-8-07

- Overvoltage category II applies to mains filters.
- Install the mains filter as close to the driver as possible.
- Use cable clamps and other means to secure the input and output cables firmly to the surface of the enclosure.
- Connect the ground terminal of the mains filter to the grounding point, using as thick and short a wire as possible.
- Do not place the AC input cable (AWG18 to 14: 0.75 to 2.0 mm²) parallel with the mains-filter output cable (AWG18 to 14: 0.75 to 2.0 mm²). Parallel placement will reduce mains filter effectiveness if the enclosure's internal noise is directly coupled to the power supply cable by means of stray capacitance.

■ Connecting the AC power line reactor

When inputting single-phase 200-240 V, insert a reactor (5 A, 5 mH) in the AC power line to ensure compliance with EN 61000-3-2.

■ Connecting the external power supply

Use an external power supply conforming to the EMC Directive. Use a shielded cable for wiring the external power supply over the shortest possible distance. Refer to "Wiring the power supply cable" for how to ground the shielded cable.

■ How to ground

The cable used to ground the motor, driver, mains filter and power supply cable (shielded cable) must be as thick and short to the grounding point as possible so that no potential difference is generated. Choose a large, thick and uniformly conductive surface for the grounding point. Refer to the p.15 for the recommended grounding method.

■ Wiring the power supply cable

Use a shielded cable of AWG18 to 14 (0.75 to 2.0 mm²) in diameter for the driver power supply cable and keep it as short as possible. Strip a part of the shielded cable and ground the stripped part using a metal cable clamp that contacts the stripped cable around its entire circumference, or use a drain wire to make the ground connection.

When grounding the shielded cable, connect both ends (mains filter side and power supply side) to earth to prevent a potential difference from generating in the shielded cable.

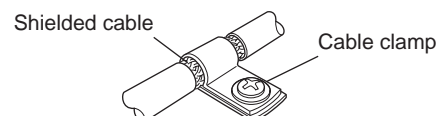

■ Notes about installation and wiring

- Connect the motor/driver and other peripheral control equipment directly to the grounding point so as to prevent a potential difference from developing between grounds.
- When relays or electromagnetic switches are used together with the system, use mains filters and CR circuits to suppress surges generated by them.
- Keep cables as short as possible without coiling and bundling extra lengths.
- Wire the power lines such as the motor cable and power cable away from the signal cables by providing a minimum clearance of 100 mm (3.94 in.) between them. If they must cross, do so at a right angle. Place the AC input cable and output cable of a mains filter separately from each other.
- Use a connection cable (supplied or accessory) when extending the wiring distance between the motor and driver. The EMC measures are conducted using the Oriental Motor connection cable.

■ Example of motor and driver installation and wiring

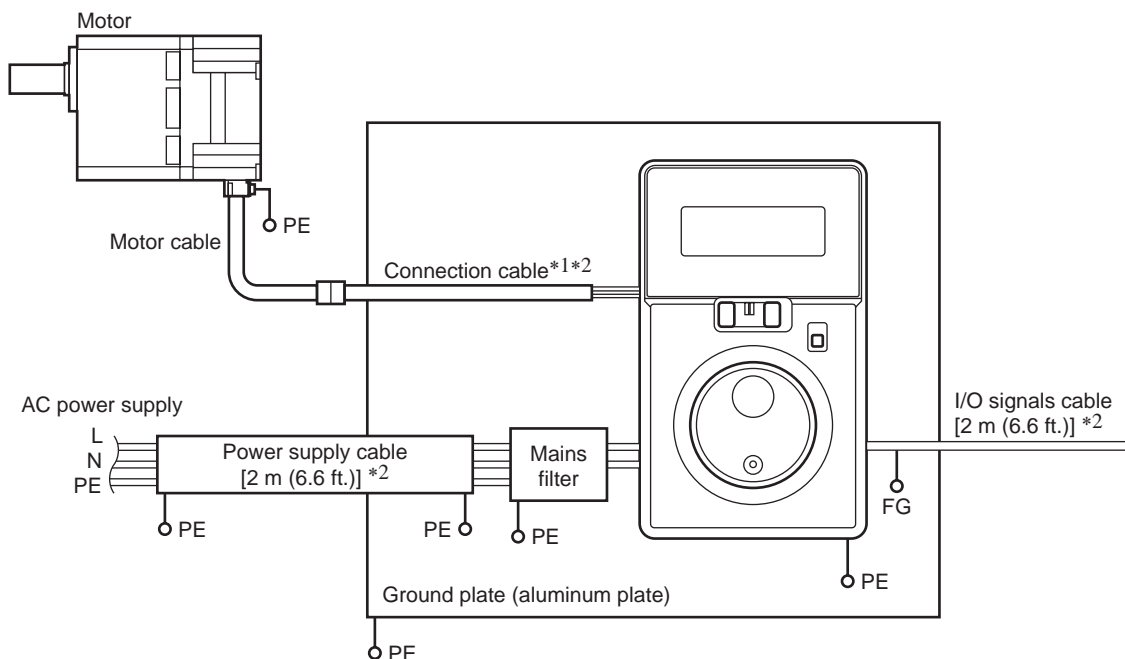

*1 Performance has been evaluated based on connection cable lengths of up to 10 m (32.8 ft.). You can connect up to two connection cables.

*2 Shielded cable

■ Precautions about static electricity

Static electricity may cause the driver to malfunction or suffer damaged. Except when operating the setting dial, potentiometer or switches on the driver front panel, do not come to close or touch the driver while the driver power is ON. To change the settings of driver acceleration/deceleration time potentiometer, be sure to use an insulated screwdriver.

11.3 Specifications

- in the model names indicates a number representing the gear ratio.
- indicates the cable length (-1, -2, -3) when the connection cable is supplied.
- ◆ in the model name indicates **A** (no machining) or **AC** (shaft flat) for the round shaft type.

Model	Combination type parallel shaft gearhead	BMU230A-□■* BMU230AP-□■*	BMU230C-□■* BMU230CP-□■*	BMU460SA-□■* BMU460SAP-□■*	BMU460SC-□■* BMU460SCP-□■*
	Round shaft type	BMU230A-◆■ BMU230AP-◆■	BMU230C-◆■ BMU230CP-◆■	BMU260A-◆■ BMU260AP-◆■	BMU260C-◆■ BMU260CP-◆■
Rated output power (Continuous)		30 W		60 W	
Power supply input	Rated voltage	Single-phase 100-120 V	Single-phase 200-240 V Three-phase 200-240 V	Single-phase 100-120 V	Single-phase 200-240 V Three-phase 200-240 V
	Permissible voltage range	-15 to +10%			
	Rated frequency	50/60 Hz			
	Permissible frequency range	±5%			
	Rated input current	1.2 A	Single-phase: 0.7 A Three-phase: 0.38 A	1.7 A	Single-phase: 1.0 A Three-phase: 0.52 A
	Maximum input current	2.0 A	Single-phase: 1.2 A Three-phase: 0.75 A	3.3 A	Single-phase: 1.9 A Three-phase: 1.1 A
Rated torque		0.096 N·m (13.6 oz-in)		0.191 N·m (27 oz-in)	
Instantaneous peak torque		0.144 N·m (20 oz-in) [80 to 2000 r/min]		0.287 N·m (41 oz-in) [80 to 2000 r/min]	
Rated rotation speed		3000 r/min			
Speed control range		80 to 4000 r/min			

Model	Combination type parallel shaft gearhead	BMU5120A-□■* BMU5120AP-□■*	BMU5120C-□■* BMU5120CP-□■*
	Round shaft type	BMU5120A-◆■ BMU5120AP-◆■	BMU5120C-◆■ BMU5120CP-◆■
Rated output power (Continuous)		120 W	
Power supply input	Rated voltage	Single-phase 100-120 V	Single-phase 200-240 V Three-phase 200-240 V
	Permissible voltage range	-15 to +10%	
	Rated frequency	50/60 Hz	
	Permissible frequency range	±5%	
	Rated input current	3.3 A	Single-phase: 2.0 A Three-phase: 1.1 A
	Maximum input current	6.8 A	Single-phase: 4.1 A Three-phase: 2.0 A
Rated torque		0.382 N·m (54 oz-in)	
Instantaneous peak torque		0.573 N·m (81 oz-in) [80 to 2000 r/min]	
Rated rotation speed		3000 r/min	
Speed control range		80 to 4000 r/min	

* The value in a state where the gearhead is not combined is described in each specification for the "rated torque," "instantaneous peak torque," "rated rotation speed" and "speed control range."

General specifications

Operation environment	Ambient temperature	0 to +40 °C [+32 to +104 °F] (non-freezing)
	Ambient Humidity	85% or less (non-condensing)
	Altitude	Up to 1000 m (3300 ft.) above sea level
	Surrounding atmosphere	No corrosive gas, dust, water or oil. Cannot be used in radioactive materials, magnetic field, vacuum or other special environment.
	Vibration	Not subject to continuous vibrations or excessive impact In conformance with JIS C 60068-2-6 "Sine-wave vibration test method" Frequency range: 10 to 55 Hz Pulsating amplitude: 0.15 mm (0.006 in.) Sweep direction: 3 directions (X, Y, Z) Number of sweeps: 20 times
Storage environment	Ambient temperature	-25 to +70 °C [-13 to +158 °F] (non-freezing)
	Ambient Humidity	85% or less (non-condensing)
	Altitude	Up to 3000 m (10000 ft.) above sea level
	Surrounding atmosphere	No corrosive gas, dust, water or oil. Cannot be used in radioactive materials, magnetic field, vacuum or other special environment.
Shipping environment	Ambient temperature	-25 to +70 °C [-13 to +158 °F] (non-freezing)
	Ambient Humidity	85% or less (non-condensing)
	Altitude	Up to 3000 m (10000 ft.) above sea level
	Surrounding atmosphere	No corrosive gas, dust, water or oil. Cannot be used in radioactive materials, magnetic field, vacuum or other special environment.
Degree of protection		Motor Standard type: IP20 IP65 type: IP65 (excluding the connector part and the mounting surface of the round shaft type).
		Driver: IP20

- Unauthorized reproduction or copying of all or part of this manual is prohibited.
If a new copy is required to replace an original manual that has been damaged or lost, please contact your nearest Oriental Motor branch or sales office.
- Oriental Motor shall not be liable whatsoever for any problems relating to industrial property rights arising from use of any information, circuit, equipment or device provided or referenced in this manual.
- Characteristics, specifications and dimensions are subject to change without notice.
- While we make every effort to offer accurate information in the manual, we welcome your input. Should you find unclear descriptions, errors or omissions, please contact the nearest office.
- **Orientalmotor** is a registered trademark or trademark of Oriental Motor Co., Ltd., in Japan and other countries.
Other product names and company names mentioned in this manual may be registered trademarks or trademarks of their respective companies and are hereby acknowledged. The third-party products mentioned in this manual are recommended products, and references to their names shall not be construed as any form of performance guarantee. Oriental Motor is not liable whatsoever for the performance of these third-party products.

© Copyright ORIENTAL MOTOR CO., LTD. 2013

- Please contact your nearest Oriental Motor office for further information.

ORIENTAL MOTOR U.S.A. CORP.
Technical Support Tel:(800)468-3982
8:30 A.M. to 5:00 P.M., P.S.T. (M-F)
7:30 A.M. to 5:00 P.M., C.S.T. (M-F)
E-mail: techsupport@orientalmotor.com
www.orientalmotor.com

ORIENTAL MOTOR (EUROPA) GmbH
Headquarters and Düsseldorf Office
Tel:0211-52067-00 Fax:0211-52067-099
Munich Office
Tel:089-3181225-00 Fax:089-3181225-25
Hamburg Office
Tel:040-76910443 Fax:040-76910445

ORIENTAL MOTOR (UK) LTD.
Tel:01256-347090 Fax:01256-347099

ORIENTAL MOTOR (FRANCE) SARL
Tel:01 47 86 97 50 Fax:01 47 82 45 16

ORIENTAL MOTOR ITALIA s.r.l.
Tel:02-93906346 Fax:02-93906348

SHANGHAI ORIENTAL MOTOR CO.,LTD.
Tel:400-820-6516 Fax:021-6278-0269

TAIWAN ORIENTAL MOTOR CO.,LTD.
Tel:(02)8228-0707 Fax:(02)8228-0708

SINGAPORE ORIENTAL MOTOR PTE LTD
Tel:+65-6745-7344 Fax:+65-6745-9405

ORIENTAL MOTOR (MALAYSIA) SDN. BHD.
Tel:(03)22875778 Fax:(03)22875528

ORIENTAL MOTOR (THAILAND) CO.,LTD.
Tel:+66-2-251-1871 Fax:+66-2-251-1872

INA ORIENTAL MOTOR CO.,LTD.
KOREA
Tel:080-777-2042 Fax:02-2026-5495

ORIENTAL MOTOR CO.,LTD.
Headquarters Tokyo, Japan
Tel:03-6744-0361 Fax:03-5826-2576